



# INSTRUCTION MANUAL

## HF TRANSCEIVER **IC-78**



## IMPORTANT

**READ THIS INSTRUCTION MANUAL CAREFULLY** before attempting to operate the transceiver.

**SAVE THIS INSTRUCTION MANUAL.** This manual contains important safety and operating instructions for the IC-78.

## EXPLICIT DEFINITIONS

WORD	DEFINITION
⚠ <b>DANGER!</b>	Personal death, serious injury or an explosion may occur.
⚠ <b>WARNING!</b>	Personal injury, fire hazard or electric shock may occur.
<b>CAUTION</b>	Equipment damage may occur.
<b>NOTE</b>	Recommended for optimum use. No risk of personal injury, fire or electric shock.

## SUPPLIED ACCESSORIES

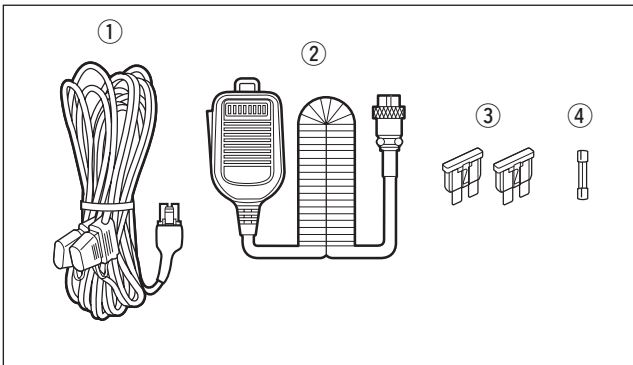

The transceiver comes with the following accessories.

	Qty.
① DC power cable .....	1
② Hand microphone (HM-36) .....	1
③ Fuse (ATQ 25 A; for DC cable).....	2
④ Fuse (FGB 4 A; internal use) .....	1

Icom, Icom Inc. and Icom logo are registered trademarks of Icom Incorporated (Japan) in Japan, the United States, United Kingdom, Germany, France, Spain, Russia, Australia, New Zealand, and/or other countries.

## PRECAUTIONS

⚠ **DANGER HIGH VOLTAGE! NEVER** touch an antenna connector during transmission. This may result in an electrical shock or burn.

⚠ **WARNING! NEVER** operate the transceiver while driving a vehicle. Safe driving requires your full attention—anything less may result in an accident.

⚠ **WARNING! NEVER** operate the transceiver with an earphone or other audio accessories at high volume levels. Continuous high volume operation may cause a ringing in your ears. If you experience ringing, reduce the volume level or discontinue use.

⚠ **WARNING! NEVER** connect the transceiver to an AC outlet. This may pose a fire hazard or result in an electric shock.

⚠ **WARNING! NEVER** connect the transceiver to a power source of more than 16 V DC such as a 24 V DC. This could cause a fire or damage the transceiver.

⚠ **WARNING! NEVER** reverse the DC power cable polarity when connecting to a power source. This could damage the transceiver.

⚠ **WARNING! NEVER** cut the DC power cable between the DC plug and fuse holder. If an incorrect connection is made after cutting, the transceiver may be damaged.

⚠ **WARNING! NEVER** let metal, wire or other objects touch any internal part or connectors on the rear panel of the transceiver. This may result in an electric shock or this could cause a fire or damage the transceiver.

⚠ **WARNING! NEVER** operate or touch the transceiver with wet hands. This may result in an electric shock or may damage the transceiver.

⚠ **WARNING!** Immediately turn the transceiver power OFF and remove the power cable if it emits an abnormal odor, sound or smoke. Contact your Icom dealer or distributor for advice.

**CAUTION: NEVER** expose the transceiver to rain, snow or any liquids.

**CAUTION: NEVER** change the internal settings of the transceiver. This may reduce transceiver performance and/or damage to the transceiver.

**CAUTION: NEVER** place the transceiver where normal operation of the vehicle may be hindered or where it could cause bodily injury.

**DO NOT** operate the transceiver near unshielded electrical blasting caps or in an explosive atmosphere.

**DO NOT** push the PTT when not actually desiring to transmit.

---

# TABLE OF CONTENTS

---

**DO NOT** use harsh solvents such as benzine or alcohol to clean the transceiver, as they will damage the transceiver's surfaces. If the transceiver becomes dusty or dirty, wipe it clean with a soft, dry cloth.

**DO NOT** operate or place the transceiver in areas with temperatures below  $-10^{\circ}\text{C}$  ( $+14^{\circ}\text{F}$ ) or above  $+60^{\circ}\text{C}$  ( $+140^{\circ}\text{F}$ ).

Be aware that temperatures on a vehicle's dashboard can exceed  $+80^{\circ}\text{C}$  ( $+176^{\circ}\text{F}$ ) in direct sunlight, resulting in permanent damage to the transceiver if left there for extended periods.

**DO NOT** place the transceiver in excessively dusty environments or in direct sunlight.

**DO NOT** place the transceiver against walls or put anything on top of the transceiver. This will obstruct heat dissipation.

Place the transceiver in a secure place to avoid inadvertent use by children.

During mobile operation, **NEVER** place the transceiver where air bag deployment may be obstructed.

During mobile operation, **DO NOT** place the transceiver where hot or cold air blows directly onto it.

During mobile operation, **DO NOT** operate the transceiver without running the vehicle's engine. When transceiver power is ON and your vehicle's engine is OFF, the vehicle's battery will soon become exhausted.

Make sure the transceiver power is OFF before starting the vehicle engine. This will avoid possible damage to the transceiver by ignition voltage spikes.

During maritime mobile operation, keep the transceiver and microphone as far away as possible from the magnetic navigation compass to prevent erroneous indications.

**BE CAREFUL!** The heatsink will become hot when operating the transceiver continuously for long periods of time.

**BE CAREFUL!** If a linear amplifier is connected, set the transceiver's RF output power to less than the linear amplifier's maximum input level, otherwise, the linear amplifier will be damaged.

Use only supplied or optional Icom microphones. Other manufacturer's microphones have different pin assignments, and connecting to the IC-78 may damage the transceiver.

IMPORTANT .....	i
EXPLICIT DEFINITIONS.....	i
SUPPLIED ACCESSORIES.....	i
PRECAUTIONS.....	i, ii
<b>1 PANEL DESCRIPTION .....</b>	<b>1 – 6</b>
■ Front panel .....	1
■ Function display .....	3
■ Rear panel.....	4
■ Microphone (HM-36) .....	6
<b>2 INSTALLATION AND CONNECTIONS .....</b>	<b>7 – 11</b>
■ Unpacking .....	7
■ Selecting a location .....	7
■ Grounding .....	7
■ Antenna connection .....	7
■ Required connections .....	8
■ Advanced connections .....	9
■ Connecting the Power supply .....	10
■ External antenna tuners .....	11
<b>3 OPERATION.....</b>	<b>12– 26</b>
■ Selecting a channel.....	12
■ Frequency indication .....	13
■ Lock function .....	13
■ Scan function .....	13
■ Basic voice receive and transmit.....	14
■ Mode selection .....	14
■ RF gain and Squelch.....	14
■ Functions for transmit.....	15
■ Functions for receive.....	18
■ Filter selection .....	20
■ Filter setting.....	21
■ Functions for CW .....	22
■ Functions for RTTY .....	24
■ Channel name entry.....	26
<b>4 SET MODE .....</b>	<b>27– 32</b>
■ General .....	27
■ Quick Set mode items .....	28
■ Initial Set mode items.....	30
<b>5 EXTRA FEATURES .....</b>	<b>33– 35</b>
■ Introduction .....	33
■ VFO operation.....	33
■ 2-Tone alarm operation.....	35
<b>6 OPTION INSTALLATION.....</b>	<b>36– 37</b>
■ Opening the transceiver's case.....	36
■ Optional bracket and carrying handle .....	36
■ CR-338 HIGH STABILITY CRYSTAL UNIT .....	37
■ Optional IF filters .....	37
<b>7 MAINTENANCE .....</b>	<b>38– 39</b>
■ Troubleshooting .....	38
■ Fuse replacement .....	39
■ Resetting the CPU .....	39
<b>8 REMOTE JACK INFORMATION .....</b>	<b>40– 41</b>
■ CI-V remote control .....	40
■ Data cloning between transceivers .....	41
<b>9 SPECIFICATIONS.....</b>	<b>42</b>
<b>10 OPTIONS .....</b>	<b>43– 44</b>

## Front panel

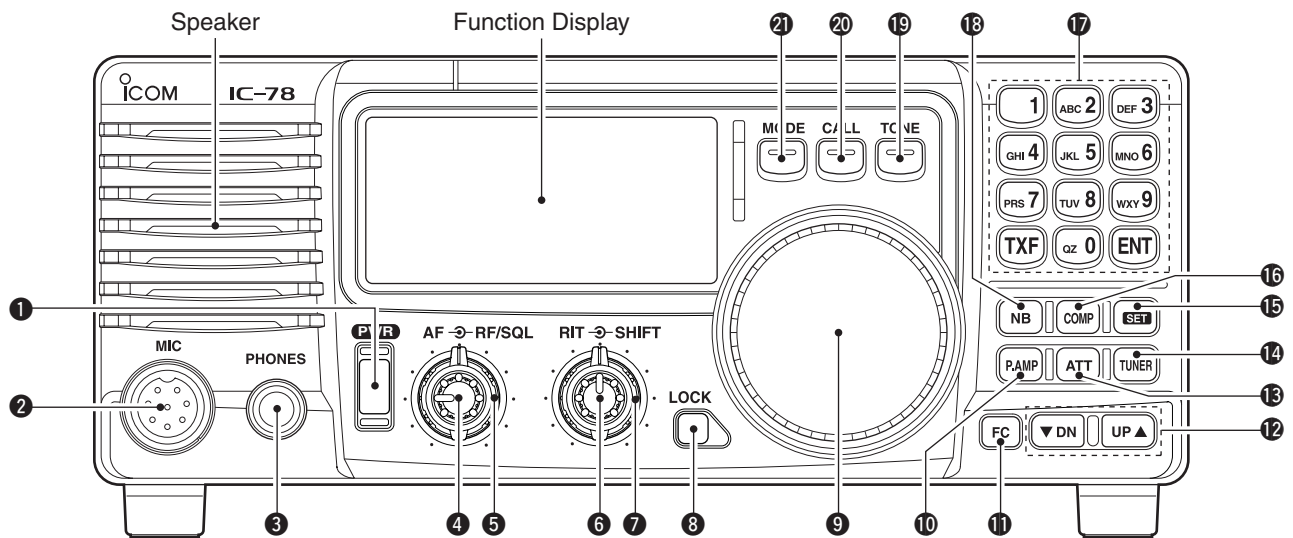

### 1 POWER SWITCH [PWR]

- ➔ Push to turn ON the power.
  - First, confirm the DC power supply is ON.
- ➔ Hold down for 1 second to turn OFF the power.
- ➔ While holding down [SET], push [PWR] to enter the Initial Set mode. (p. 27)

### 2 MICROPHONE CONNECTOR [MIC]

- Accepts the supplied or optional microphone.
- See page 45 for appropriate microphones.
- See page 7 for microphone connector information.

### 3 HEADPHONE JACK [PHONES] (p. 9)

- Accepts headphones.
- When headphones are connected, the internal or external speaker does not function.

### 4 AF CONTROL [AF] (inner control)

- Adjusts the audio output level.

### 5 RF GAIN/SQUELCH CONTROL [RF/SQL]

- (outer control, pp. 14, 30)
- Adjusts the squelch threshold level. The squelch removes noise output from the speaker (closed) when no signal is received.
- The squelch is available for all modes.
- The control can be set as the squelch plus RF gain controls or squelch control only (RF gain is fixed at maximum) in the Initial Set mode.

### 6 RIT CONTROL [RIT] (inner control, p. 18)

- ➔ Shifts the receive frequency  $\pm 1.2$  kHz for clear reception of an off frequency signal.
- Rotate the control clockwise to increase the frequency, or counterclockwise to decrease the frequency. "RIT" is displayed on the display.

### 7 IF SHIFT CONTROLS [SHIFT]

- (outer control, p. 19)
- Shifts the center frequency of the receiver's IF passband.
- Rotate the control clockwise to shift the center frequency higher, or counterclockwise to shift the center frequency lower.

### 8 LOCK SWITCH [LOCK] (p. 13)

- Push to turn the dial lock function ON or OFF.
- The dial lock function electronically locks the Channel Selector.

### 9 CHANNEL SELECTOR

- Selects an operating channel, selects values in the Quick/Initial Set mode items, and so on.

### 10 PREAMP SWITCH [P.AMP] (p. 18)

- Push to turn the preamp ON or OFF.

### 11 FC SWITCH [CH]

- ➔ Push to change the indication, channel name or stored frequency. (p. 13)
- ➔ **This key action only for some versions.**
- ➔ Hold down for 1 second to enter the VFO mode. (p. 34)

### 12 MEMORY CHANNEL UP/DOWN SWITCHES

- [▼ DN]/[UP ▲]
- ➔ Push to select the desired Memory channel. (p. 12)
- ➔ Hold down for 1 second to start scanning. (p. 13)
- ➔ Push to select the Quick/Initial Set mode items while the Quick/Initial Set mode is selected. (p. 27)
- ➔ Push to select the character while editing the channel name. (p. 26)

**13 ATTENUATOR SWITCH [ATT]** (p. 18)

Push to turn the 20 dB attenuator function ON or OFF.

**14 TUNER SWITCH [TUNER]** (p. 17)

- Push to turn the antenna tuner function ON or OFF.
- Hold down for 1 second to manually tune the tuner.
  - An optional antenna tuner must be connected.
  - When the tuner cannot tune the antenna, the tuning circuit is automatically bypassed after 20 seconds.

**15 SET SWITCH [SET]**

- Hold down for 1 second to enter the Quick Set mode. (p. 27)
- Hold down [SET], then push [PWR] to enter the Initial Set mode. (p. 27)
- Push to change the meter function. (p. 15)
  - PO: Displays the relative RF output power.
  - ALC: Displays ALC level.
  - SWR: Displays the SWR over the transmission line.

**16 MIC COMPRESSOR SWITCH [COMP]** (p. 16)

Turn the mic compressor function ON or OFF.

**17 KEYPAD**

The Keypad can be used for several functions as described below:

- [0] to [9]
  - To enter an operating channel number. (p. 12)
  - Select a character when entering a channel name. (p. 26)
- [ENT]
  - Direct channel number input. (p. 12)
- [TXF]
  - Transmit frequency display. (p. 13)
  - Selects a space and changes the editing digit when entering channel name. (p. 26)

**18 NOISE BLANKER SWITCH [NB]** (p. 18)

- Turns the noise blanker ON or OFF. The noise blanker reduces pulse-type noise such as that generated by automobile ignition systems. This function is not effective against non pulse-type noise.
- Hold down [NB] for 1 second to enter the noise blanker level setting mode.

**19 TONE SWITCH [TONE]**

- **This key action may differ, depending on the transceiver version.**
- Selects the Call channel and emits a distress alarm tone from the speaker. (p. 35)
- Transmits a distress alarm or alarm test signal when held down for 1 second. (p. 35)
  - Cancels the distress alarm tone sound, or distress alarm transmission.
- Directly selects the tuning step item in the Quick Set mode.
- No function is assigned, depending on the transceiver version.

**20 CALL SWITCH [CALL]**

- Push to select the Call channel.
  - Push again to return to previous condition.

**21 MODE SWITCH [MODE]** (p. 14)

- Push to change an operating mode.
- Hold down [MODE] for 1 second during SSB mode to switch between LSB or USB.
  - Hold down [MODE] for 1 second during CW or RTTY mode, to switch between CW and CW reverse or RTTY and RTTY reverse. “**REV**” is displayed on the display.

## ■ Function display

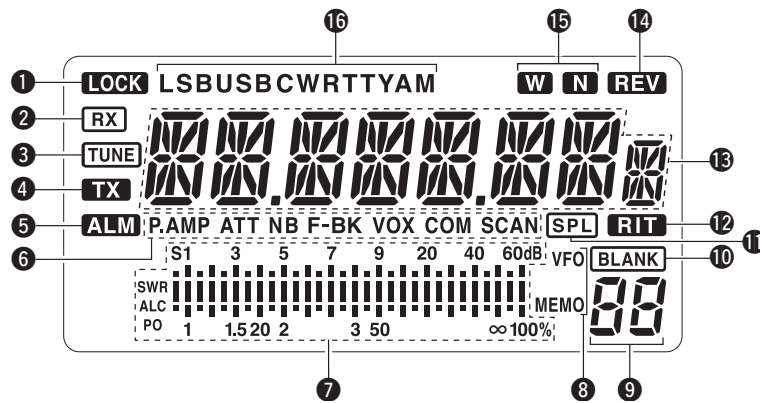

### 1 LOCK ICON (p. 13)

Displays when the dial lock function is in use.

### 2 RECEIVE ICON

Displays while receiving a signal or when the squelch is open.

### 3 TUNE ICON

- Displays or disappears when the connected automatic tuner is tuned completely, depending on connected antenna tuner type.
- Blinks while tuning.

### 4 TRANSMIT ICON

- Displays while transmitting.
- Blinks while transmit frequency is displayed.

### 5 ALARM ICON

➤ **This icon is displayed only some versions.**  
Displays while 2-tone alarm sounding or transmitting

### 6 FUNCTION ICONS

- “P.AMP” is displayed when preamp is activated.
- “ATT” is displayed when the RF attenuator is activated.
- “NB” is displayed when the Noise Blanker is activated.
- “BK” is displayed when the semi break-in function is selected in the Quick Set mode.
- “F-BK” is displayed when the full break-in function activates in CW mode. (p. 22)
- “VOX” is displayed when the VOX function is selected in the Quick Set mode.
- “COM” is displayed when the speech compressor activates in SSB mode.
- “SCAN” is displayed during scanning.
  - Blinks when scan is paused.

### 7 SIGNAL/SQL/RF-GAIN METER

- Functions as an S-meter while receiving.
- Functions as a Power, ALC or SWR meter while transmitting. (p. 15)

### 8 VFO/MEMORY ICON

- “MEMO” is displayed during regular operation.
- **This icon is displayed only some versions.**
- “VFO” is displayed during VFO operation.

### 9 CHANNEL NUMBER READOUT (p. 12)

Shows the selected channel number.

### 10 BLANK ICON

Displays when no frequency programmed channel is selected.

### 11 SPLIT ICON (p. 12)

Displays when the duplex channel, in which different frequencies between transmit and receive are programmed, is selected.

### 12 RIT ICON (p. 18)

Displays when the RIT function is in use.

### 13 CHANNEL READOUT

Shows the memory names, or stored frequency of the selected channel.

### 14 REVERSE ICON (p. 14)

Displays when the CW reverse or RTTY reverse mode is selected.

### 15 WIDE/NARROW FILTER ICONS (pp. 20, 21)

- “W” is displayed when the wide IF filter is selected.
- “N” is displayed when the narrow IF filter is selected.

### 16 MODE ICONS (p. 14)

Indicates the temporarily selected operating mode.

## ■ Rear panel

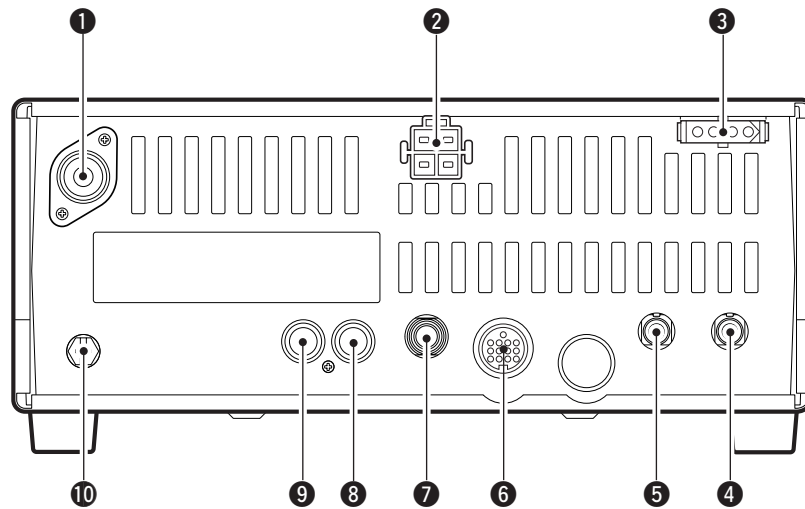

**1 ANTENNA TERMINAL [ANT]** (p. 8)  
Connects a 50 Ω antenna with a PL-259 connector and a 50 Ω coaxial cable.

**2 DC POWER SOCKET [DC 13.8V]** (p. 10)  
Accepts 13.8 V DC through the supplied DC power cable.

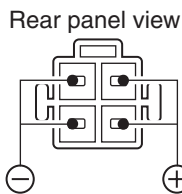

**3 TUNER CONTROL SOCKET [TUNER]** (p. 9)  
Accepts the control cable from an optional antenna tuner.

**4 REMOTE JACK [REMOTE]** (p. 9)  
For use with a personal computer for remote operation of the transceiver's functions, and for data cloning between transceivers.

**5 EXTERNAL SPEAKER JACK [EXT SP]**  
Connects an 8 Ω external speaker, if desired.  
• When an external speaker is connected, the internal speaker does not function.

**6 ACCESSORY SOCKET [ACC]** (p. 5)  
Connects to external equipment such as a TNC for data communications or a linear amplifier, and so on.

**7 ELECTRONIC KEYS JACK [KEY]**  
Accepts a paddle to use the internal electronic keyer.  
• Selection between the internal electronic keyer and straight key operation can be made in the Initial Set mode.

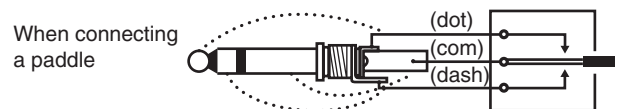
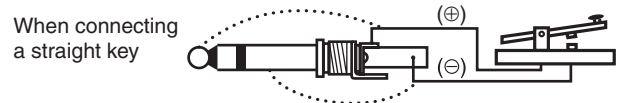

**8 ALC INPUT JACK [ALC]**  
Connects to the ALC output jack of a non-Icom linear amplifier.

**9 SEND CONTROL JACK [SEND]**  
Goes to ground while transmitting to control external equipment such as a linear amplifier.  
• Max. control level: 16 V DC/2 A

**10 GROUND TERMINAL [GND]** (p. 8)  
Connects to ground.

# 1 PANEL DESCRIPTION

## ◇ ACC SOCKET INFORMATION

### • ACC socket

ACC	PIN #	NAME	DESCRIPTION	SPECIFICATIONS
 <p>Rear panel view</p>	1	8 V	Regulated 8 V output.	Output voltage: 8 V $\pm$ 0.3 V Output current: Less than 10 mA
	2	GND	Connects to ground.	—
	3	SEND	Input/output pin. Goes to ground when transmitting. When grounded, transmits.	Ground level: -0.5 V to 0.8 V Input current: Less than 20 mA
	4	BDT	Data line.	—
	5	BAND	Band voltage output.	
	6	ALC	ALC voltage output.	Control voltage: -4 V to 0 V Input impedance: More than 10 k $\Omega$
	7	NC	—	—
	8	13.8 V	13.8 V output when power is ON.	Output current: Maximum 1 A
	9	TKEY	Key line.	—
	10	FSKK	RTTY key input.	Ground level: -0.5 V to 0.8 V Input current: Less than 10 mA
	11	MOD	Modulation input.	Input impedance: 10 k $\Omega$ Input level: Approximately 100 mV rms
	12	AF	AF detector output. Fixed, regardless of [AF] position.	Output impedance: 4.7 k $\Omega$ Output level: 100–300 mV rms
	13	SQLS	Squelch output. Goes to ground when squelch opens.	SQL open: Less than 0.3 V/5 mA SQL closed: More than 6.0 V/100 $\mu$ A

### • When connecting the ACC conversion cable (OPC-599)

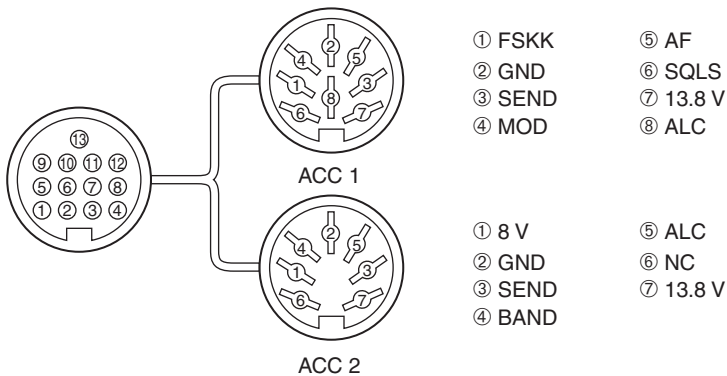

When the SEND terminal controls an inductive load (such as a relay), a counter-electromotive force can cause the transceiver to malfunction or other damage. To prevent this, we recommend adding a switching diode, such as an “1SS133,” on the load side of the circuit to the counter-electromotive force absorption. When the diode is added, a switching delay of the relay may occur. Be sure to check its switching action before operation.

#### [Example]

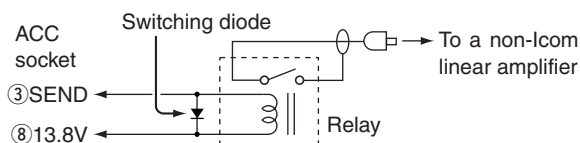



## Microphone (HM-36)

### DESCRIPTION

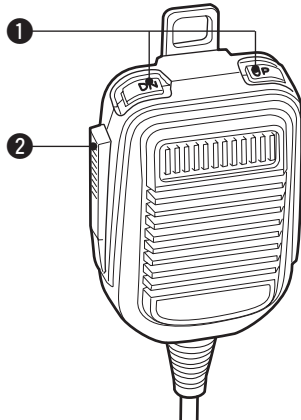

#### 1 UP/DOWN SWITCHES [UP]/[DN]

Change the selected frequency or Memory channel.

- Holding down continuously changes the frequency or Memory channel number.
- The [UP]/[DN] switch can be used as a paddle key. Set in the CW PADDL of the Initial Set mode. (p. 31)

#### 2 PTT SWITCH

Hold down to transmit, release to receive.

### MICROPHONE CONNECTOR

(Front view)

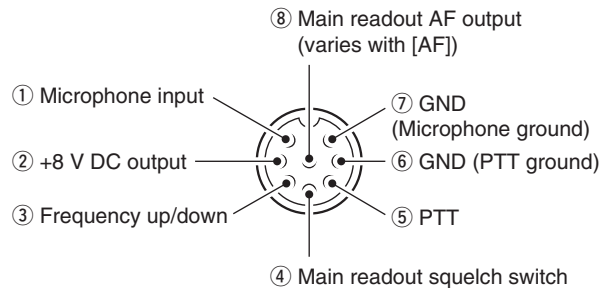

[MIC] Pin No.	FUNCTION	DESCRIPTION
②	+8 V DC output	Maximum 10 mA
③	Frequency up	Ground
	Frequency down	Ground through 470 Ω
④	Squelch open	“Low” level
	Squelch closed	“High” level

**CAUTION: DO NOT** short pin 2 to ground as this can damage the internal 8 V regulator. DC voltage is also applied to pin 1 for microphone operation. Use caution when using a non-Icom microphone.

### HM-36 SCHEMATIC DIAGRAM

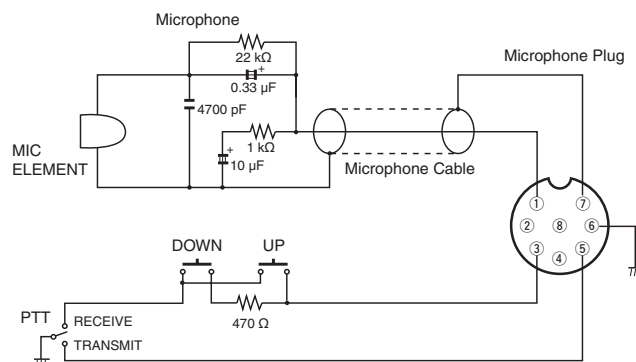

## ■ Unpacking

After unpacking, immediately report any damage to the delivering carrier or dealer. Keep the shipping cartons.

For a description and a illustration of accessory equipment included with the IC-78, see 'Supplied accessories' on page i of this manual.

## ■ Selecting a location

Select a location for the transceiver that allows adequate air circulation, free from extreme heat, cold, or vibration, and away from TV sets, and other electromagnetic sources.

The base of the transceiver has an adjustable stand for desktop use. Set the stand to one of two angles depending on your operating conditions.

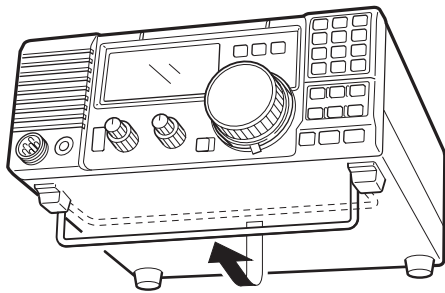

## ■ Grounding

To prevent electrical shock, television interference (TVI), broadcast interference (BCI) and other problems, ground the transceiver through the GROUND terminal on the rear panel.

For best results, connect a heavy gauge wire or strap to a long earth-sunk copper rod. Make the distance between the [GND] terminal and the rod as short as possible.

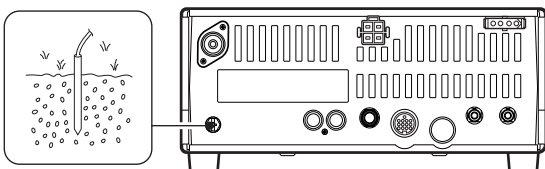

**⚠ WARNING: NEVER** connect the [GND] terminal to a gas or electric pipe, since the connection could cause an explosion or electric shock.

## ■ Antenna connection

For radio communications, the antenna is of critical importance, along with output power and sensitivity. Select antenna(s), such as a well-matched 50  $\Omega$  antenna, and feed line. 1.5:1 or better of Voltage Standing Wave Ratio (VSWR) is recommended for your desired band. The transmission line should be a coaxial cable.

**⚡ CAUTION:** Help protect your transceiver from lightning by using a lightning arrestor or better, disconnect the antenna during lightning storms.

### Antenna SWR

Each antenna is tuned for a specified frequency range and SWR may be increased out of that range. When the SWR is higher than approximately 2.0:1, the transceiver's power drops to protect the final transistor. In this case, an antenna tuner is useful to match the transceiver and antenna. Low SWR allows near full power for transmitting even when using the antenna tuner. The IC-78 has an SWR meter to continuously monitor the antenna SWR.

## ■ Required connections

### • Front panel

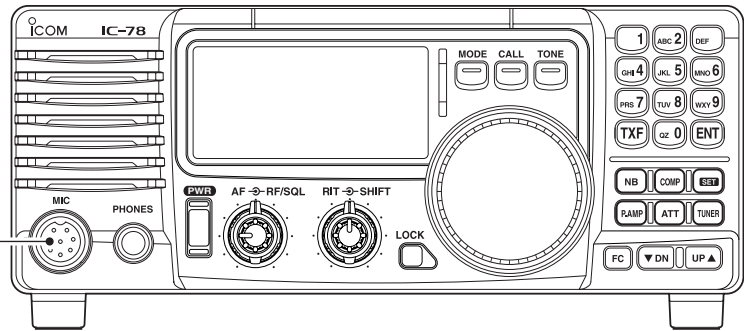
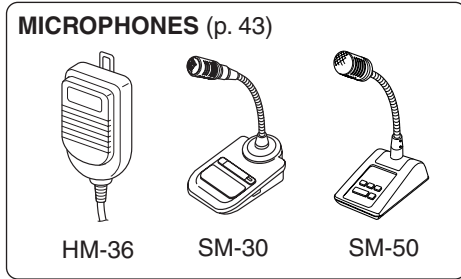

### • Rear panel

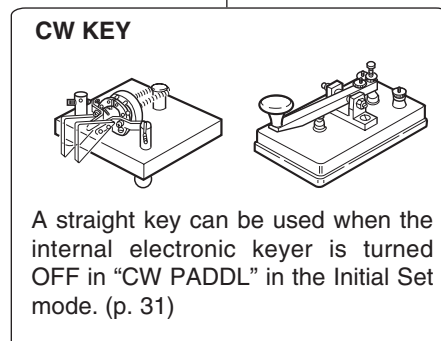
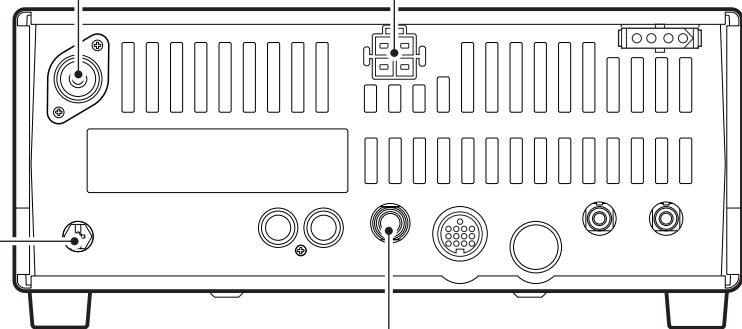
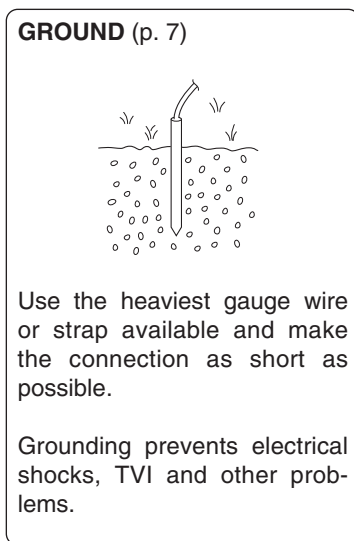
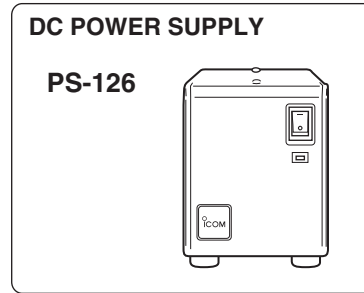
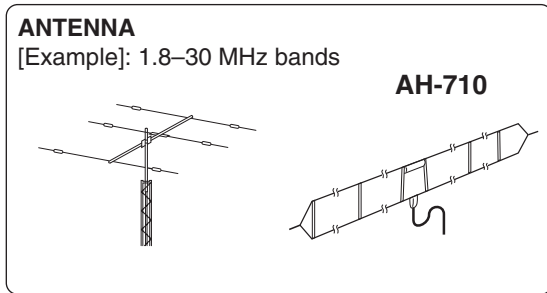

## ■ Advanced connections

### • Front panel

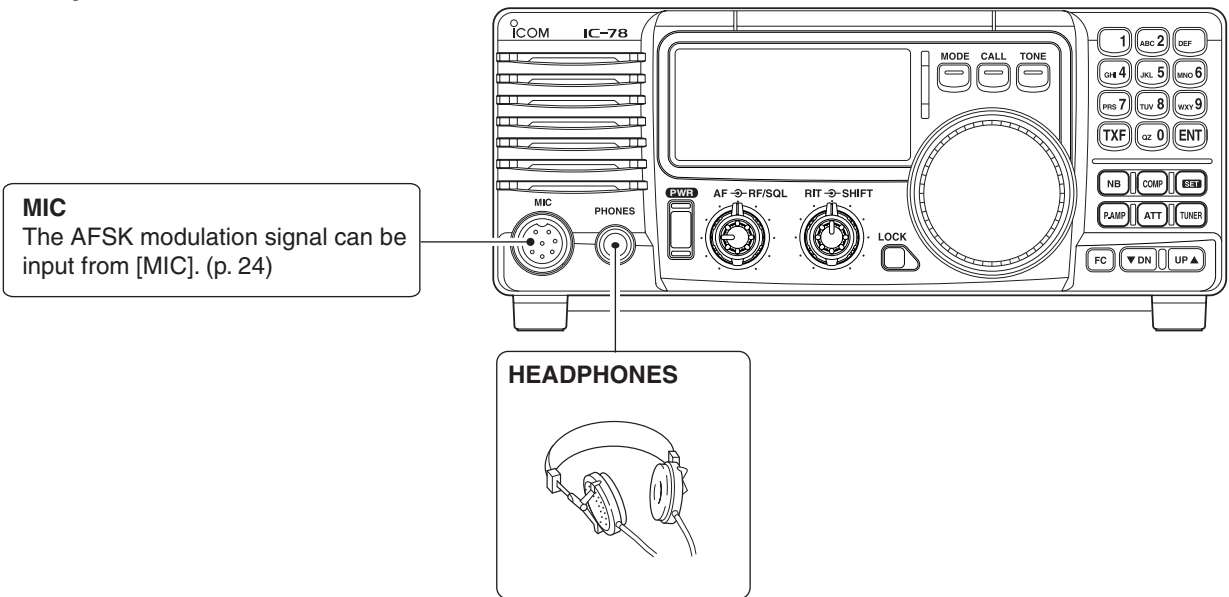

### • Rear panel

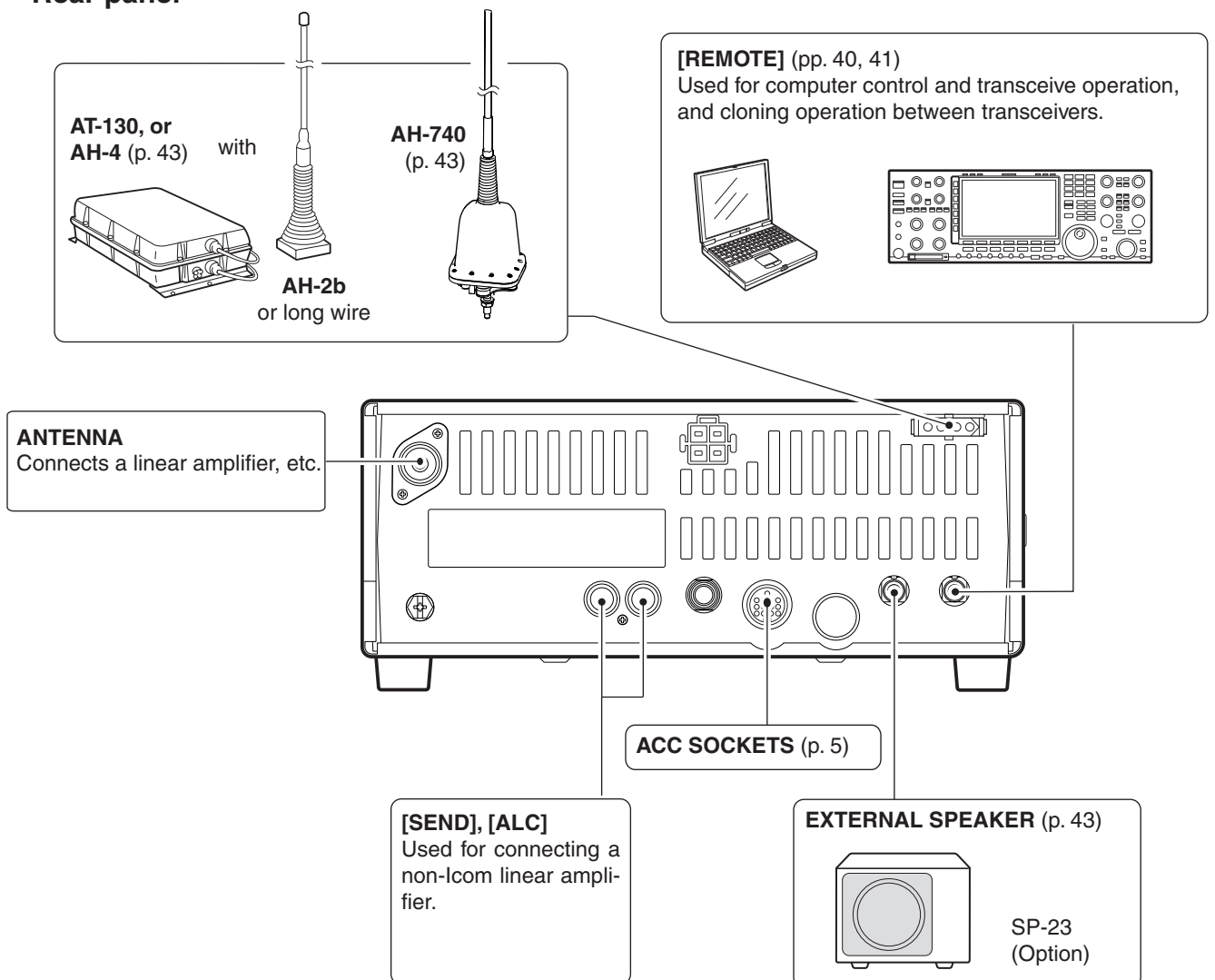

## ■ Connecting the Power supply

Use an optional PS-126 DC POWER SUPPLY when operating the IC-78 with AC power. Refer to the diagrams below.

**CAUTION:** Before connecting the DC power cable, check the following important items. Make sure:

- The [POWER] switch is OFF.
- Output voltage of the power source is 12 to 15 V when you use a non-Icom power supply.
- DC power cable polarity is correct.  
Red: Positive ⊕ terminal  
Black: Negative ⊖ terminal

### CONNECTING THE PS-126 DC POWER SUPPLY

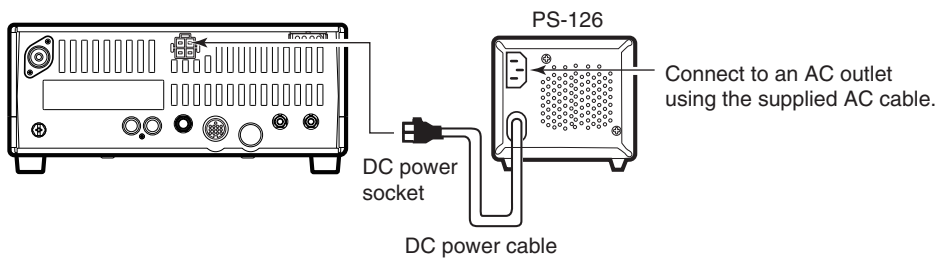

### CONNECTING A NON-ICOM DC POWER SUPPLY

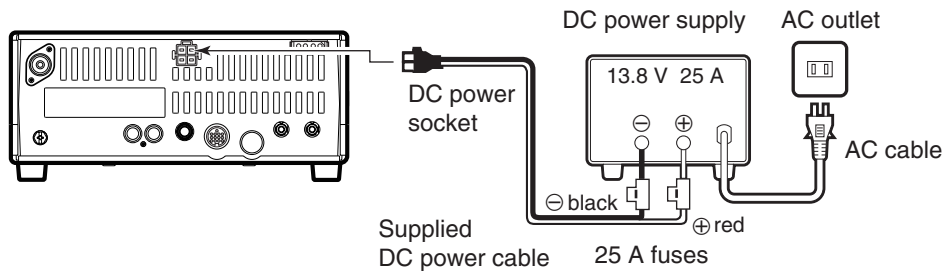

### CONNECTING A VEHICLE BATTERY

- **⚠ WARNING! NEVER** connect to a battery without using a DC fuse, otherwise a fire hazard could occur or damage to the transceiver.
- **NEVER** connect the transceiver to a 24 V battery.

The transceiver may not receive well on some frequencies when installed in a hybrid vehicle, or any type of electric vehicle (fuel cell vehicle). This is because vehicle's electric components, such as the inverter system, generate a lot of electric noise.

- **DO NOT** use a cigarette lighter socket as a power source when operating in a vehicle. The plug may cause voltage drops and ignition noise may be superimposed onto transmit or receive audio.
- Use a rubber grommet when passing the DC power cable through a metal plate to prevent a short circuit.

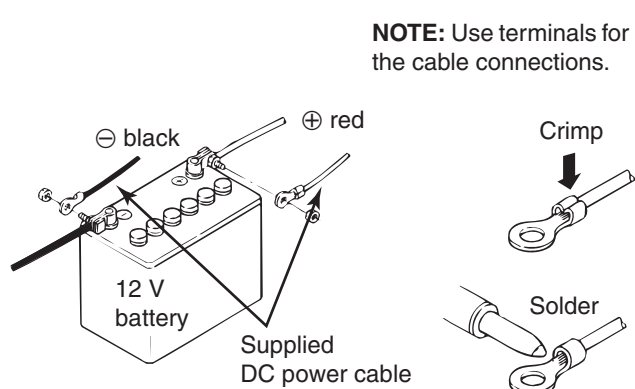
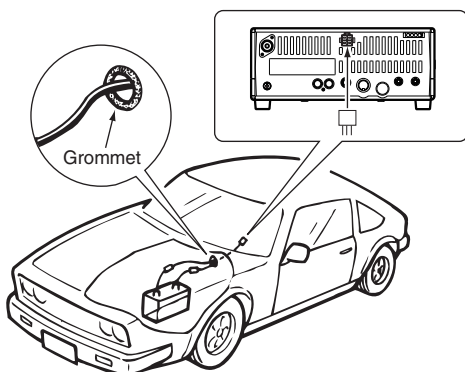

**NOTE:** Use terminals for the cable connections.

## External antenna tuners

### CONNECTING AN ANTENNA TUNER (p. 43)

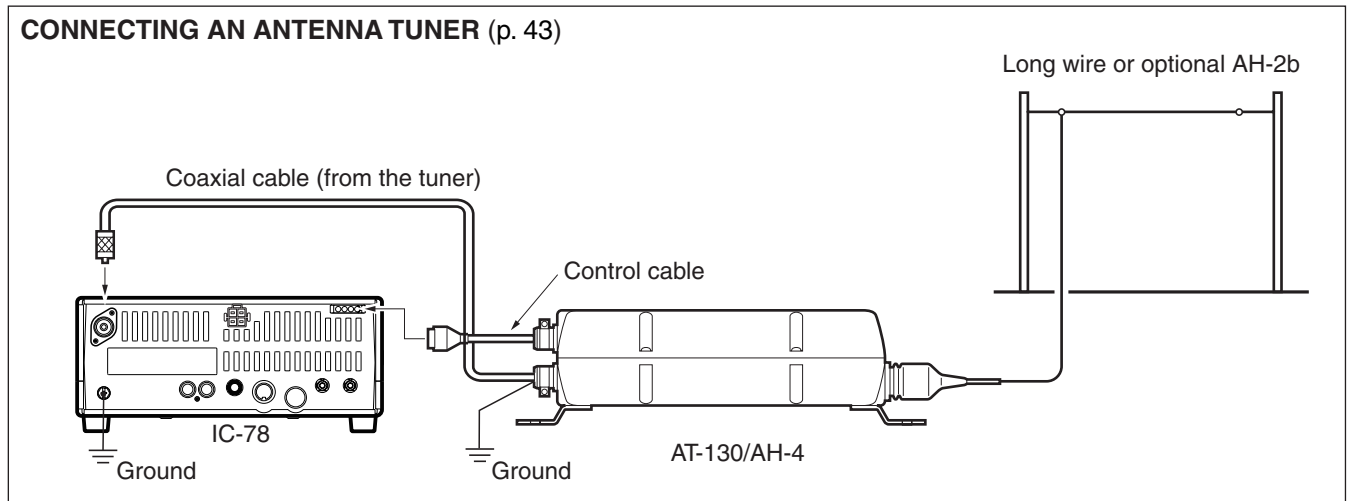

### CONNECTING THE AH-740 (p. 29)

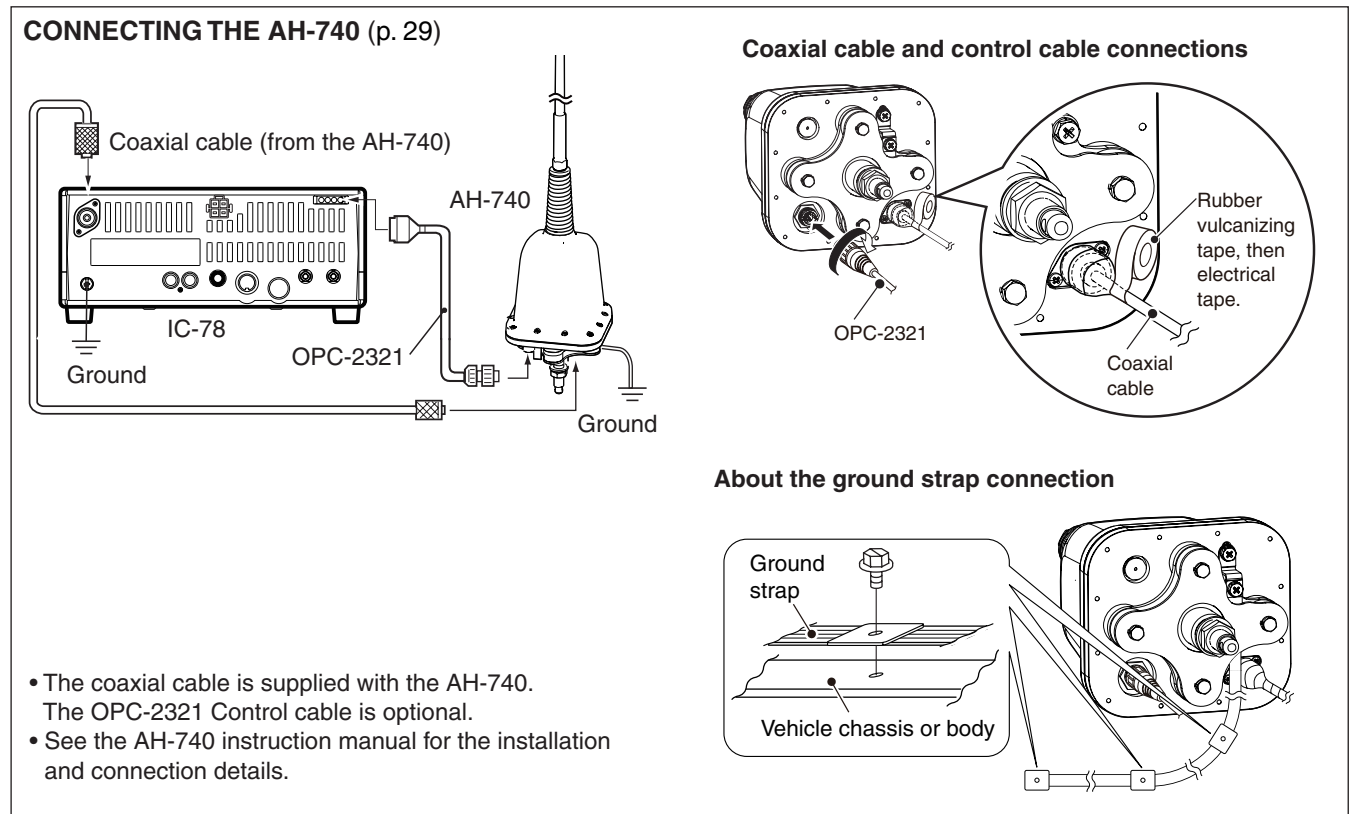

## ■ Selecting a channel

The transceiver has 99 memory channels. However, the number of channels can be restricted in the Initial Set mode (p. 30) depending on your needs. A total of 3 ways of channel selections are available to suit your operating style.

### ◇ Using the Channel Selector

Rotate the Channel Selector clockwise (channel number increases) or counterclockwise (channel number decreases) to select desired channel.

This is the most useful way of channel selection.

### ◇ Using up/down switches

Push [UP ▲] or [▼ DN] on the front panel or the microphone to select the desired channel.

This way is convenient when changing a small number of channels.

- When a duplex channel (different frequencies between transmit and receive) is selected, “[SPL]” is displayed.

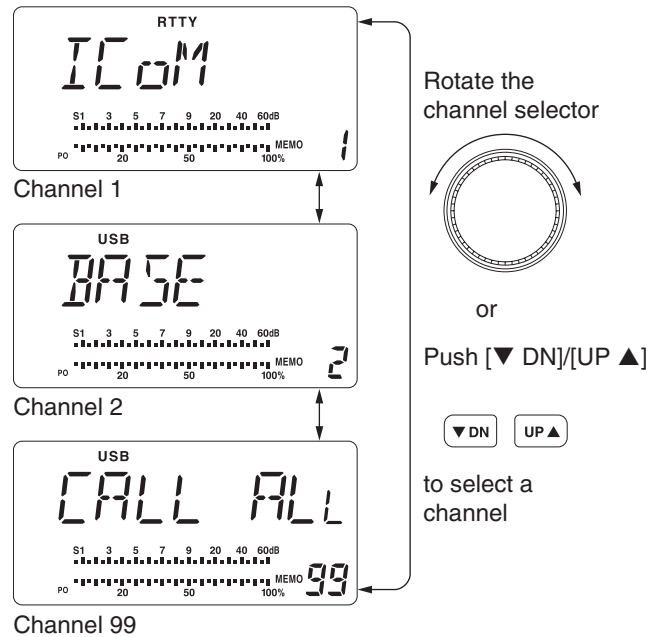

### ◇ Using the Keypad

Enter the number of the desired channel number using the Keypad (0 to 9), then push [ENT].

This way is convenient for remembering the usage and stored channel number, or when changing large a number of channels.

- When a duplex channel (different frequencies between transmit and receive) is selected, “[SPL]” is displayed.
- When a blank channel (no frequency is programmed) is selected, “[BLANK]” is displayed.

#### • Example 1— selecting channel 8

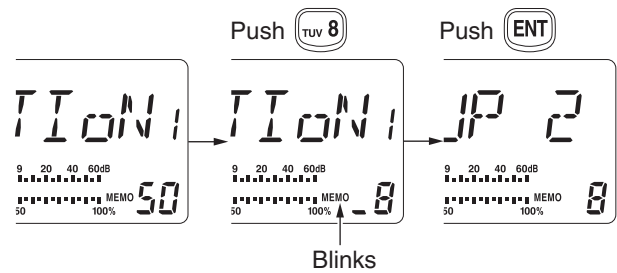

#### • Example 2— selecting channel 25

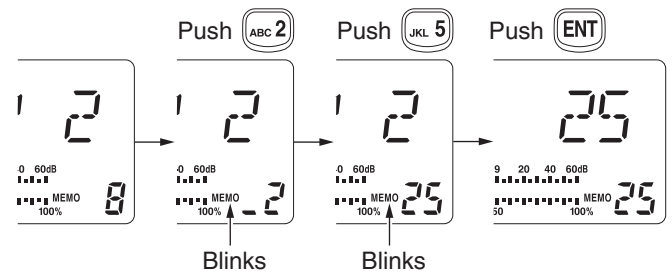

## Frequency indication

Push [FC] to display the channel name or channel frequency.

### ◇ Transmit frequency indication

Push [TXF] to display the transmit frequency instead of the channel name or operating frequency.

When the transmit frequency is displayed, "TX" blinks.

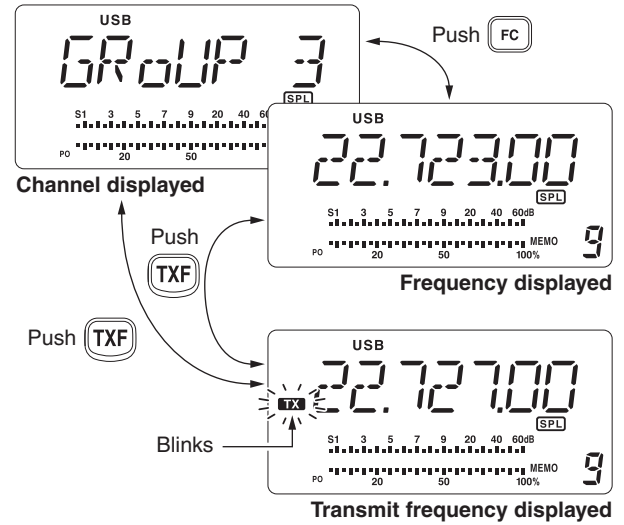

## Lock function

The lock function electronically locks the Channel Selector to prevent accidentally changing channels.

Push [LOCK] to turn the Lock function ON or OFF. Before selecting a channel, turn OFF this function.

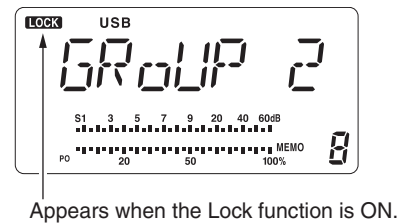

Appears when the Lock function is ON.

## Scan function

The Scan function repeatedly scans programmed channels. This function is convenient to wait for calls on multiple channels.

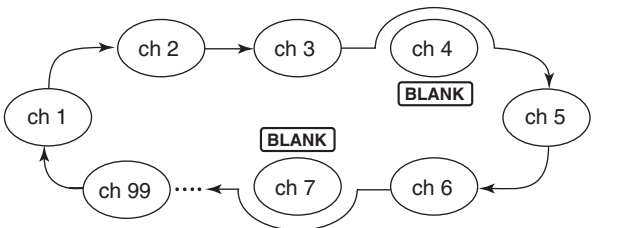

① Set [RF/SQL] control to the center (12 o'clock) position (opening squelch), then rotate the control clockwise to the position where the noise just disappears.

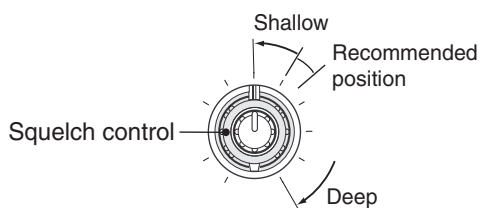

② Hold down [UP ▲] or [▼ DN] for 1 second to start a Channel scan.  
• The "SCAN" icon appears.

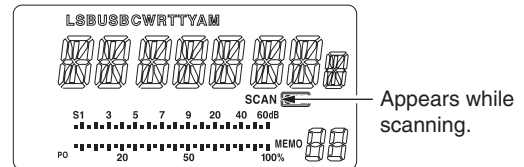
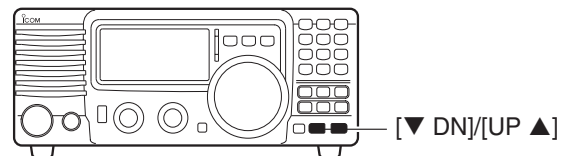

Appears while scanning.

③ When a signal is received, the scan pauses on that channel.  
④ Push [UP ▲] or [▼ DN] to cancel the scan.

**NOTE:** The scan resume operation (the action after receiving a signal) can be set to "scan resume" or "scan cancel" in the Initial Set mode (p. 30).



## Basic voice receive and transmit

- ① Check the following in advance:
  - ➔ Microphone is connected.
  - ➔ [AF] control is set to minimum position.
  - ➔ [RF/SQL] is set to center position (squelch open).
  - ➔ [RIT] control set to center position.

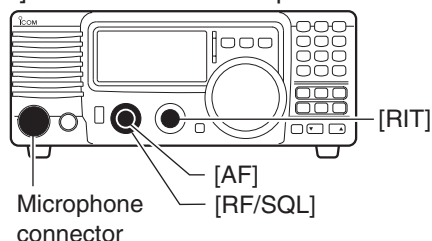

- ② Selects the desired channel to be received with the Channel Selector, [UP ▲] or [▼ DN], or 10-key pad.
  - The S-meter shows signal strength when signal is received.

- ③ Adjust [AF] to the desired audio level when receiving a signal.
- ④ Push [MODE] to select the desired operation mode, if the received signal is in a different mode.
- ⑤ If the bass or treble of the receive audio is too strong, rotate [RIT] control to obtain clear audio. (p. 18)
- ⑥ Push [TUNER] to tune the antenna tuner, if connected.
  - The “TUNE” icon blinks for 1 to 2 seconds for the first tuning on a channel.
- ⑦ Hold down [PTT] on the microphone, and speak into the microphone at a normal voice level.
  - The RF meter shows the output power according to your voice level, when RF power meter is selected.
- ⑧ Release [PTT] to return to receive.

## Mode selection

The following modes are available in the IC-78: SSB (LSB/USB), CW, CW REV (CW reverse), RTTY, RTTY REV (RTTY reverse) and AM.

- ➔ Push [MODE] to select desired operation mode.
- ➔ Hold down [MODE] for 1 second to change between USB and LSB, CW and CW reverse or RTTY and RTTY reverse. (SSB, CW and RTTY mode only)
- The selected mode is indicated in the function display.

**Note:** The selected mode can be used for temporary operation only.

### OPERATING MODE SELECTION

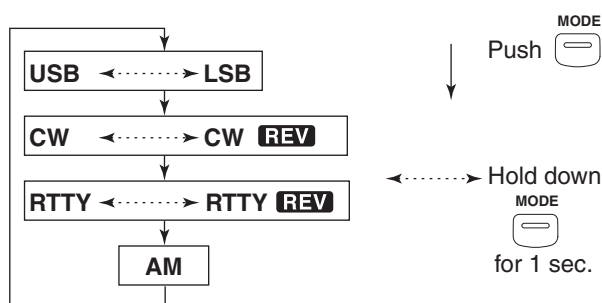

## RF gain and Squelch

The [RF/SQL] control adjusts either the RF gain or the squelch. The action depends on the operating mode and the condition of the RF/SQL item in the Initial Set mode (p. 30).

### • [RF/SQL] control priority

Set mode setting	SSB, CW, RTTY	AM
rS (RF/SQL)	RF/SQL	RF/SQL
At (Auto)	RF gain	SQL*
Sq (SQL) (default)	SQL*	SQL*

\* The RF gain is set to maximum level when the [RF/SQL] is set as [SQL] control.

The *RF gain* is used to adjust the receiver gain.

- Shallow rotation moves the S-meter to the right indicating the signal strength which can be received.

/// The recommended position for RF gain is the 12 o'clock position since this sets RF gain to the max.

The *SQUELCH* removes noise output from the speaker (closed condition) when no signal is received. The squelch is available for the other modes.

- A segment is displayed in the S-meter to indicate the S-meter squelch level.

- When set as the [RF/SQL] control

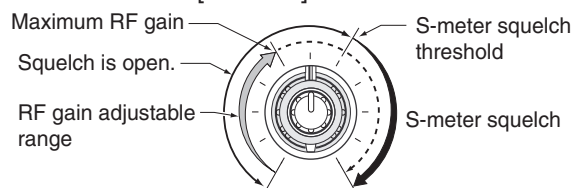

- When set as the [SQL] control

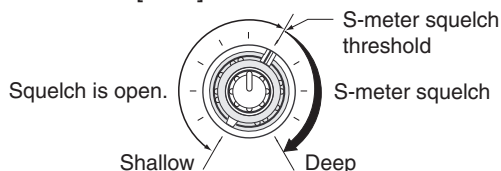

- When set as the [RF] control

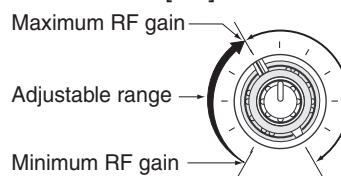

## ■ Functions for transmit

### ◇ Output power and microphone gain

#### • Setting output power

- ① Hold down [SET] for 1 second to select the Quick Set mode.
- ② Push [UP ▲] or [▼ DN] to select "RF POWER".
- ③ Rotate the main dial to select the desired output.
  - Output power is displayed in 101 steps (L, 1–99 and H) but is continuously selectable.

#### • Available power

SSB/CW/RTTY: 2 (or less) to 100 W  
 AM: 2 (or less) to 35 W\*

\*Carrier power

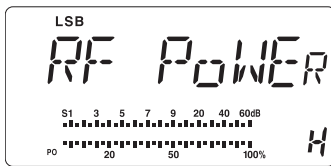

Maximum output power is selected.

#### • Setting microphone gain

Microphone gain must be adjusted properly so that your signal does not distort when transmitted.

- ① Select SSB or AM mode.
- ② Hold down [SET] for 1 second to enter the Quick Set mode.
- ③ Push [UP ▲] or [▼ DN] to select "MIC GAIN".
- ④ Adjust the mic gain while speaking into the microphone, so that the ALC meter does not exceed the ALC zone.
- ⑤ Push [SET] to exit the Quick Set mode.

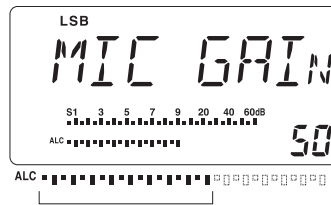

Microphone gain is set to 50.

### ◇ Meter function

The bar meter in the function display acts as an S-meter (for relative signal strength) during receive and can be selected for one of three functions during transmit.

- Push [SET] to select the PO, ALC and SWR meter mode.

#### • Measuring SWR

- ① Confirm that the output power is over 30 W.
- ② Push [SET] to select the SWR meter.
- ③ Push [MODE] to select CW or RTTY operation.
  - Key down or push [PTT] to transmit, then read the actual SWR from the meter:
    - ≤1.5; well matched antenna
    - ≥1.5; check antenna or cable connection, and so on.

Display Indication	Measurement
PO	Indicates the relative RF output power.
ALC	Indicates the ALC level. When the meter movement shows the input signal level exceeds the allowable level, the ALC limits the RF power. In such cases, reduce the microphone gain (see above).
SWR	Indicates the SWR over the transmission line.

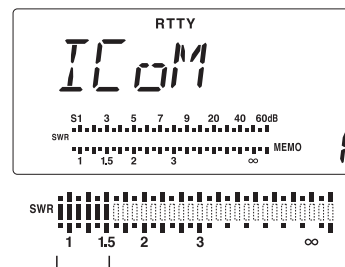

The best match is in this range.

## ◇ Microphone compressor

IC-78 has a built-in, low distortion Mic compressor circuit. This circuit increases your average talk power in SSB mode and is especially useful when the receiving station is having difficulty copying your signal.

- ① Select USB or LSB mode.
- ② Push [COMP] switch to turn mic compressor ON.
  - The “COM” icon is displayed.

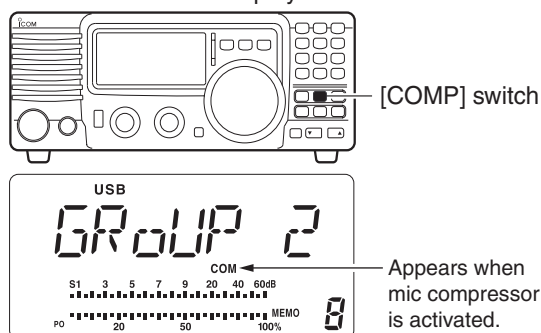

- ③ Confirm the ALC level.
  - Push [SET] to select the ALC meter.
  - Speak into the microphone at a normal voice level.
  - If the ALC meter peak past the ALC zone, re-adjust the mic. gain. (p. 15)
  - Be sure the mic gain is in the range of 20 to 50.

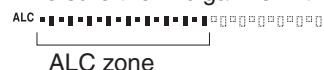

Adjust [MIC GAIN] so that the ALC meter reads within the ALC zone.

**Note:** When the ALC meter peaks above the ALC zone, your transmitted voice may be distorted.

## ◇ VOX operation

The VOX (Voice-operated Transmission) function switches between transmit and receive with your voice. This function provides an opportunity to input log entries into your computer, etc. while operating.

- ① Select “VOX” in the Quick Set mode.
  - Hold down [SET] for 1 second to select the Quick Set mode.
  - Push [UP ▲] or [▼ DN] to select “VOX”.
- ② Rotate the Channel Selector to turn VOX function ON.

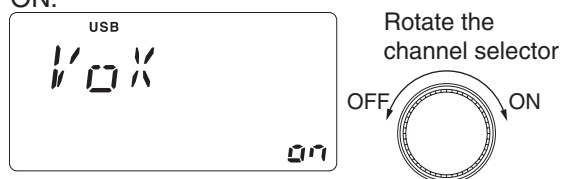

- ③ Select “VOX GAIN” in the Quick Set mode.
  - Push [UP ▲] or [▼ DN] to select “VOX”.
- ④ While speaking into the microphone, adjust [VOX GAIN] with the Channel Selector, until the transceiver is transmitting.
- ⑤ Select “VOX DELY” in the Quick Set mode.
  - Push [UP ▲] or [▼ DN] to select “VOX Delay”
- ⑥ While speaking into the microphone, adjust [VOX DELY] as desired.
- ⑦ Select “ANTI-VOX” in the Quick Set mode.
  - Push [UP ▲] or [▼ DN] one or more times to select “AN VOX”
- ⑧ If the receive audio from the speaker switches the transceiver to transmit during receive, adjust the “ANTI-VOX” to the point where it has no effect.
- ⑨ Push [SET] to exit the Quick Set mode.

#### ◇ Optional external tuner operation

**⚠ DANGER HIGH VOLTAGE!**  
**NEVER** touch the antenna element while tuning or transmitting. Always place it in a secure place.

**NEVER** operate the AT-130, AH-4 or AH-740 without an antenna connected. The tuner and transceiver will be damaged.

**NEVER** operate the AT-130, AH-4 or AH-740 if it is not grounded.

Transmitting before tuning may damage the transceiver. Note that the AT-130 or AH-4 cannot tune when using a  $1/2 \lambda$  long wire or multiple of the operating frequency.

#### **AT-130 or AH-4**

The AT-130 or AH-4 matches the IC-78 to a long wire antenna more than 7 m/23 ft long (3.5 MHz and above).

- See page 11 for connection details.
- See the Antenna tuner's instruction manual for AT-130 or AH-4 installation and connection details.

#### **AH-740**

The optional AH-740 covers 2.5 to 30 MHz range with a supplied whip antenna element. Or when using with the optional NVIS kit, it covers 2.2 to 30 MHz range.

- See page 11 for connection details.
- See the AH-740 instruction manual for the installation and connection details.

#### TUNER OPERATION

Tuning is required for each frequency. **BE SURE** to re-tune the antenna before transmitting when you change the frequency—even slightly.

#### • Tuner type setting (p. 31)

- ① Hold down [PWR] for 1 second to turn OFF the power.
- ② Enter the Initial Set mode.
  - While holding down [SET], turn power ON.
- ③ Push [UP ▲] or [▼ DN] several times to select [TUNER].
- ④ Rotate the Channel Selector to select connected antenna tuner type.
  - no: no antenna tuner is selected.
  - 4: AH-4 or AH740 is selected.
  - 12: AT-120<sup>†</sup> is selected.
  - 13: AT-130 is selected.
- ⑥ Hold down [PWR] for 1 second to turn power OFF.
- ⑦ Push [PWR] to turn power ON again.

#### • MANUAL TUNING

- ① Set the desired channel.
- ② Hold down [TUNER] for 1 second to start tuning.
  - "[TUNE]" blinks and "CW" appears while tuning.

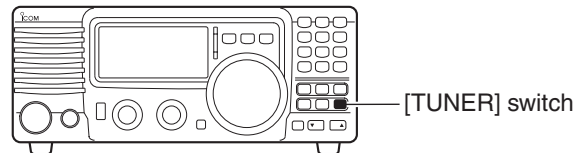

- ③ "[TUNE]" lights constantly when tuning is complete.
  - When the connected wire cannot be tuned, "[TUNE]" goes out, the antenna tuner is bypassed and the antenna wire is directly connected to the antenna connector on the transceiver.

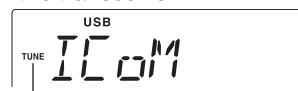

Tuning icon  
 Blinks: Tuning now  
 Appears: Tune is completed  
 Disappears: Tune cannot be not completed  
 (When AT-120<sup>†</sup> is connected, the indicator disappears even when Tune is completed.)

- ④ To manually bypass the antenna tuner, push [TUNER] to turn it OFF.
  - When AT-130 is connected, starts tuning again.

<sup>†</sup> No longer produced

## ■ Functions for receive

### ◇ RIT function

The RIT (Receive Incremental Tuning) function compensates for off-frequencies of communicating stations. The function shifts the receive frequency up to 1.2 kHz without moving the transmit frequency.

- ① Rotate the RIT control to cancel the off-frequencies.
  - “**RIT**” is displayed on the display.
  - The transmit frequencies are not shifted.

- ② To cancel the RIT function, rotate the RIT control to the center position.
  - “**RIT**” disappears.

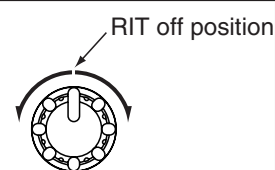

### ◇ Preamp

The preamp amplifies received signals in the front end circuit to improve the S/N ratio and sensitivity. Turn this function ON when receiving weak signals.

- ➔ Push [P.AMP] to turn the preamp ON or OFF.
  - Preamp functions below 1.6 MHz, but sensitivity may be reduced in some cases.

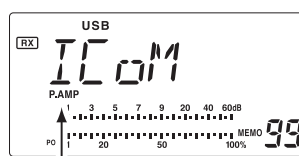

Appears when the preamp is ON.

### ◇ Attenuator

The attenuator prevents desired signals from distorting when very strong signals are near the desired frequency or when very strong electric fields, such as from broadcasting stations, are near your location.

- ➔ Push [ATT] to turn the 20 dB attenuator function ON or OFF.
  - “ATT” is displayed when the attenuator is turned ON.

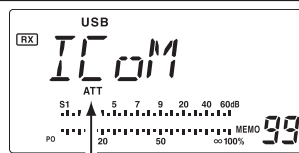

Appears when the attenuator is ON.

### ◇ Noise blanker

The *noise blanker* reduces pulse-type noise such as that generated by automobile ignition systems.

- ① Push the [NB] switch to turn the noise blanker ON.
  - The [NB] icon is displayed.
- ② Hold down the [NB] switch for 1 second to enter the noise blanker level setting condition.
- ③ Rotate the Channel Selector to adjust the noise blanker level.
- ④ Push [NB] to exit the setting condition.
- ⑤ Push [NB] again to turn the noise blanker function OFF.
  - The [NB] icon disappears.

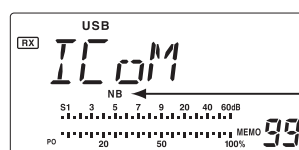
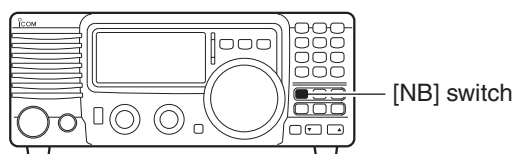

Appears when the noise blanker is ON.

- When using the noise blanker, received signals may be distorted if they are excessively strong.
- The noise blanker function in AM mode can be deactivated depending on the Initial Set mode setting. (p. 30)

### 3 OPERATION

#### ◇ Meter peak hold

The meter peak hold function freezes the highest displayed bar segment in any meter function for about 0.5 seconds so that you can more easily read the meter. This function can be turned ON or OFF in the Initial Set mode. (p. 30)



Initial reception of a signal results in an S-meter reading of 40 dB.



The highest indicated bar remains displayed for 0.5 sec. even when the signal strength decreases.

#### ◇ IF shift function

The IF shift function electronically narrows the passband frequency of the IF (intermediate frequency) and cuts out higher or lower frequency components of the IF to reject interference. The function shifts the IF frequency up to  $\pm 1.2$  kHz in SSB/CW/RTTY modes and up to  $\pm 250$  Hz in CW-narrow/RTTY narrow modes. The IF shift is not available in AM mode.

#### IF SHIFT OPERATION EXAMPLE

- Adjust the [SHIFT] control for a minimum interference signal level.
- When IF shift is used, the audio tone may be changed.
- Set the IF shift control to its center position when there is no interference.

Both controls at center position

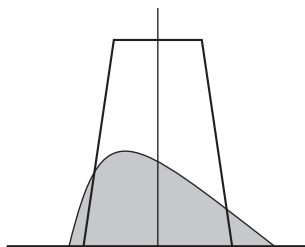
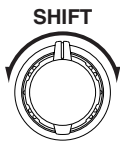

IF center frequency

Cutting a lower passband

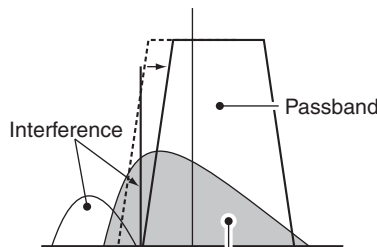
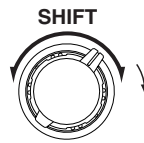

Desired signal

Cutting higher passbands

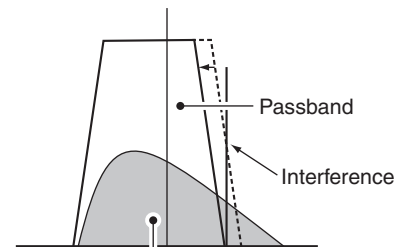
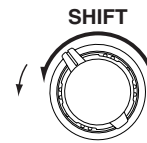

Desired signal

## Filter selection

The filter selection changes the IF passband width as shown in the table to the right.

The filter selection is for temporal setting.

- ① Select the desired mode memory channel. (p. 12)
- ② Hold down [SET] for 1 second to enter the Quick Set mode.
- ③ Push [UP ▲] or [▼ DN] several times until “FILTER” is displayed.
- ④ Rotate the Channel Selector to select a desired passband width.
  - The “W” or “N” does not appear when the normal filter is selected.
  - “W” is displayed when the wide filter is selected.
  - “N” is displayed when the narrow filter is selected.
- ⑤ Push [SET] to exit the Quick Set mode.

### Optional filter variations

Name	Band width	Mode
FL-52A†	500 Hz/−6 dB	CW/RTTY-N
FL-53A†	250 Hz/−6 dB	CW/RTTY-N
FL-96†	2.8 kHz/−6 dB	SSB-W
FL-222	1.8 kHz/−6 dB	SSB-N
FL-257	3.3 kHz/−6 dB	SSB-W

When an optional filter is installed, set the optional filter in the Initial Set mode. An optional filter is not selected by default.

### Filter construction (Rx)

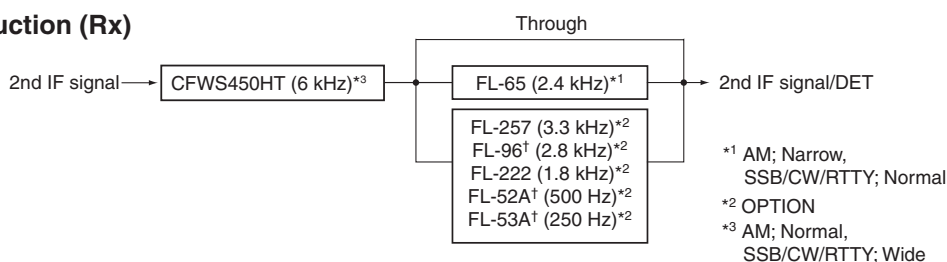

### Filter selection table

		No optional filter	FL-52A†	FL-53A†	FL-96†	FL-222	FL-257
SSB	WIDE	6 k*	6 k*	6 k*	6 k* 2.8 k	6 k*	6 k* 3.3 k
	NORMAL	2.4 k	2.4 k	2.4 k	2.4 k	2.4 k	2.4 k
	NARROW	/	500*	250*	/	1.8 k	/
CW	WIDE	6 k*	6 k*	6 k*	6 k* 2.8 k	6 k*	6 k* 3.3 k
	NORMAL	2.4 k	2.4 k	2.4 k	2.4 k	2.4 k	2.4 k
	NARROW	/	500	250	/	1.8 k	/
RTTY	WIDE	6 k*	6 k*	6 k*	6 k* 2.8 k	6 k*	6 k* 3.3 k
	NORMAL	2.4 k	2.4 k	2.4 k	2.4 k	2.4 k	2.4 k
	NARROW	/	500	250	/	1.8 k	/
AM	WIDE	/	/	/	/	/	/
	NORMAL	6 k	6 k	6 k	6 k	6 k	6 k
	NARROW	2.4 k	500*	250*	2.8 k*	1.8 k*	3.3 k*

\* This selection can be used when the expanded filter selection function is turned ON in the Initial Set mode. (see next page)

† No longer produced

## Filter setting

When an optional filter is installed, set the optional filters in the Initial Set mode. Optional filters are not selected by default. (p. 32)

### Optional filter setting

- ① While holding down [SET], push [PWR] to enter the Initial Set mode.
- ② Push [UP ▲] or [▼ DN] several times until "FIL" is displayed.
- ③ Rotate the Channel Selector to select the installed filter.
  - "no," "52A," "53A," "96," "222" or "257" indicates no optional filter, FL-52A, FL-53A, FL-96, FL-222 or FL-257, for 455 kHz IF filter selection.
- ④ Hold down [PWR] for 1 second to exit the Initial Set mode.

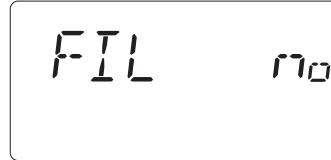

### Expanded filter selection

The selectable filter combinations can be expanded by setting the expanded filter selection to ON. Then extra wide or narrow filter can be selected in the desired mode.

- ① While holding down [SET], push [PWR] to enter the Initial Set mode.
- ② Push [UP ▲] or [▼ DN] several times until "EXP FIL" is displayed.
- ③ Rotate the Channel Selector to turn the expanded filter selection 'on'.
  - If 'on' is selected, the expanded filter selection can be used.

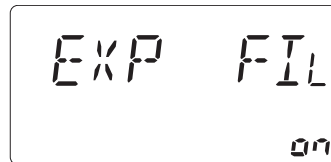

### Wide/narrow filter selection

- ④ Push [UP ▲] several times until "WIDE \*\*" or "NAR \*\*" is displayed.
- ⑤ Push [MODE] several times to select the desired mode.
- ⑥ Rotate the Channel Selector to select a filter.
- ⑦ Repeat steps ⑤ and ⑥ to select IF filters for other modes, if desired.
  - The filter combinations are stored according to the operating modes.



### Wide filter setting table

	no	FL-52A <sup>†</sup>	FL-53A <sup>†</sup>	FL-96 <sup>†</sup>	FL-222	FL-257
SSB	no	no	no	96 (2.8 kHz)	no	257 (3.3 kHz)
	THU (6 kHz)	THU (6 kHz)	THU (6 kHz)	THU (6 kHz)	THU (6 kHz)	THU (6 kHz)
CW	no	no	no	96 (2.8 kHz)	no	257 (3.3 kHz)
	THU (6 kHz)	THU (6 kHz)	THU (6 kHz)	THU (6 kHz)	THU (6 kHz)	THU (6 kHz)
RTTY	no	no	no	96 (2.8 kHz)	no	257 (3.3 kHz)
	THU (6 kHz)	THU (6 kHz)	THU (6 kHz)	THU (6 kHz)	THU (6 kHz)	THU (6 kHz)
AM	—	—	—	—	—	—

■ : default

### Narrow filter setting table

	no	FL-52A <sup>†</sup>	FL-53A <sup>†</sup>	FL-96 <sup>†</sup>	FL-222	FL-257
SSB	—	no	no	—	222 (1.8 kHz)	—
		52A (500 Hz)	53A (250 Hz)			
CW	—	52A (500 Hz)	53A (250 Hz)	—	222 (1.8 kHz)	—
RTTY	—	52A (500 Hz)	53A (250 Hz)	—	222 (1.8 kHz)	—
AM	NOR (2.4 kHz)	NOR (2.4 kHz)	NOR (2.4 kHz)	NOR (2.4 kHz)	NOR (2.4 kHz)	NOR (2.4 kHz)
		52A (500 Hz)	53A (250 Hz)	96 (2.8 kHz)	222 (1.8 kHz)	257 (3.3 kHz)

■ : default

- ⑧ Hold down [PWR] for 1 second to exit the Initial Set mode.

<sup>†</sup>No longer produced



## ■ Function for CW

### ◇ Connection for CW

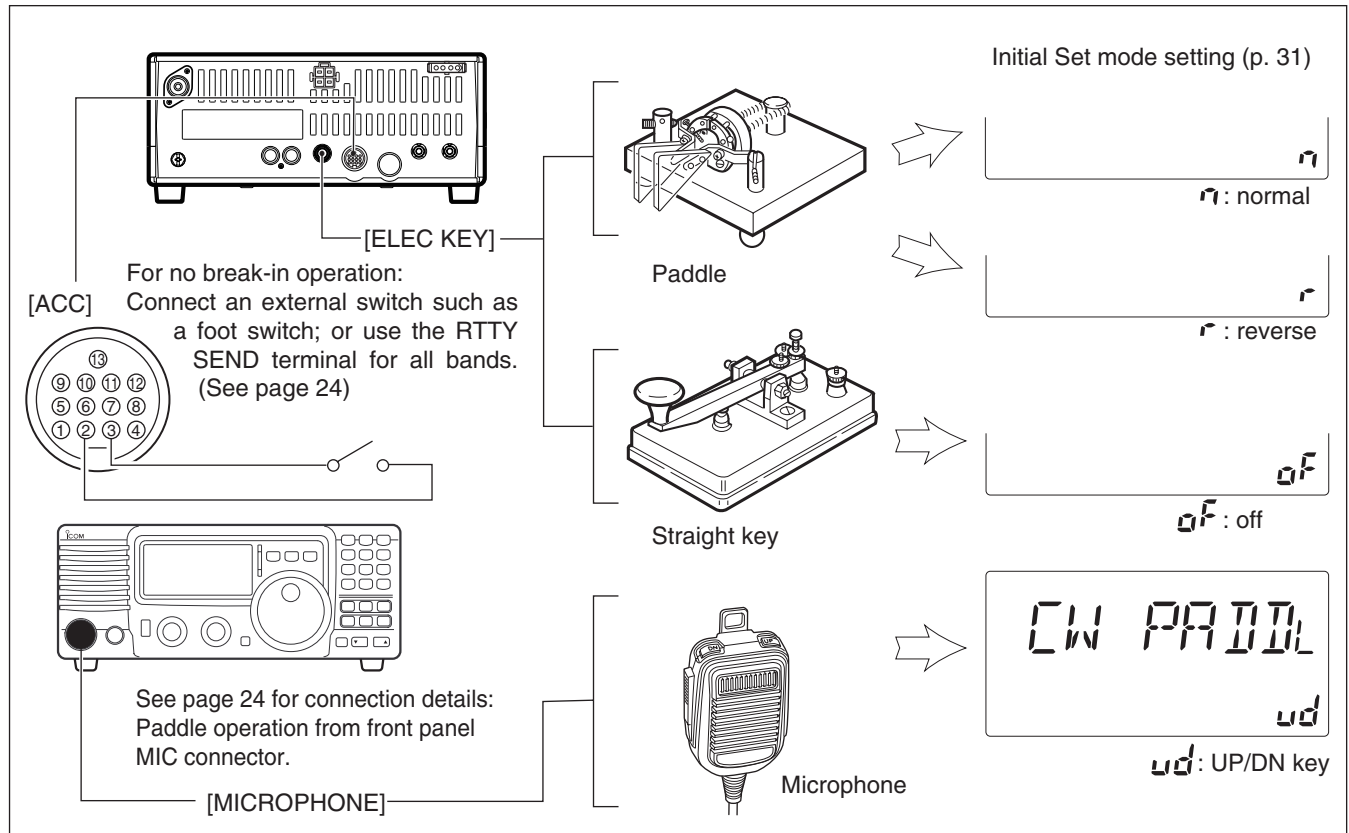

### ◇ CW operation

- ① Connect a paddle or straight key as above.
- ② Select CW (or CW-REV) programmed channel.
- ③ Set CW break-in operation as semi break-in, full break-in or OFF. (see page 29)
  - Hold down [SET] for 1 second to enter the Quick Set mode.
  - Push [UP ▲] or [▼ DN] several times until “BK-IN” is displayed, then rotate the Channel Selector to select the desired condition:  
 FL: full break-in  
 SE: semi break-in  
 oF: no break-in
- ④ Set the CW delay time when semi break-in operation is selected. (see page 29)
  - Hold down [SET] for 1 second to enter the Quick Set mode; push [UP ▲] or [▼ DN] several times until “BK-DELAY” is displayed, then rotate the Channel Selector to select the desired delay time.

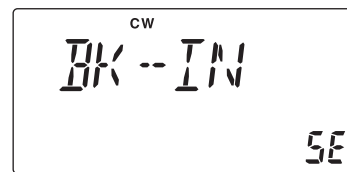

CW mode and semi break-in operation is selected.

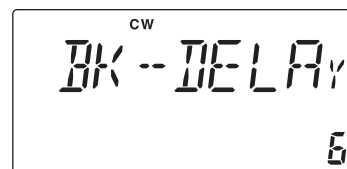

Delay time of 6 dots is selected in Quick Set mode for semi break-in operation.

### 3 OPERATION

#### ◇ CW pitch control

The received CW audio pitch and monitored CW audio pitch can be adjusted to suit your preferences (300 to 900 Hz) without changing the operating frequency.

- ① Hold down [SET] for 1 second to enter the Quick Set mode.
- ② Push [UP ▲] or [▼ DN] one or more times until “CW PITCH” is displayed, then rotate the main dial to set the desired pitch. (p. 28)

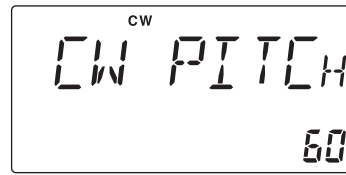

This shows the default setting for the CW pitch control (600 Hz).

#### ◇ CW reverse mode

The CW-R (CW Reverse) mode receives CW signals with a reverse side CW carrier point like that of LSB and USB modes. Use this mode when interference signals are near the desired signal and you want to change the interference tone.

- ① Push [MODE] one or more times to select CW mode.
- ② Hold down [MODE] for 1 second to switch between CW and CW-R modes.

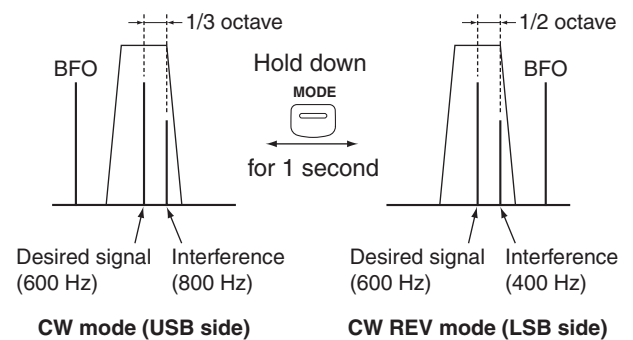

#### ◇ Electronic CW keyer

The IC-78 has an electronic keyer. Both keying speed and weight (the ratio of dot : space : dash) can be set in the Quick Set mode.

##### • Setting the electronic keyer

- ① Push [MODE] one or more times to select CW mode.
- ② While holding down [SET], push [PWR] to enter the Initial Set mode.
- ③ Push [UP ▲] or [▼ DN] one or more times until “CW PADDL” is displayed, then rotate the main dial to select the paddle type.
  - When “ud” is selected, the up/down switches on the microphone can be used as a paddle.
  - When using up/down switches as a paddle, squeeze keying function is not available.
- ④ Push [UP ▲] or [▼ DN] one or more times until “KEY RAT” is displayed, then rotate the main dial to select the desired weight.
  - Key weight can be selected from 2.8 to 4.5.
- ⑤ Push [UP ▲] or [▼ DN] one or more times until “KEY SPD” is displayed, then rotate the main dial to select the desired weight.
  - Key weight can be selected from 6 to 60.

##### Paddle operation from front panel MIC connector

Connect a CW paddle as at right to operate an electronic keyer from the front panel MIC connector.

##### KEYING WEIGHT EXAMPLE: morse code “K”

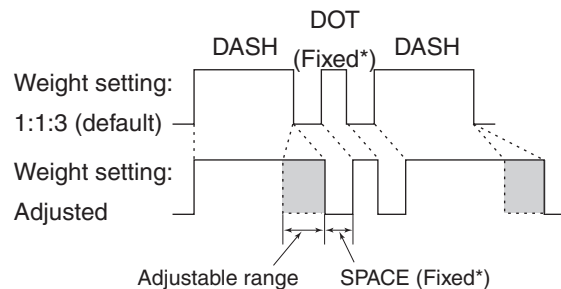

\*SPACE and DOT length can be adjusted with “KEY SPD” in the quick set mode only.

##### Paddle operation

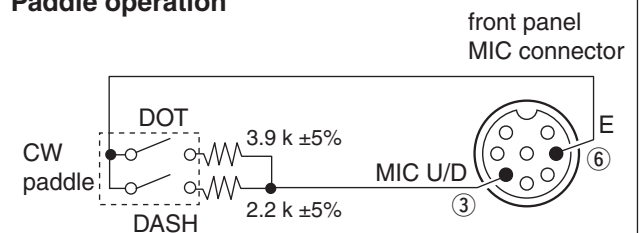

- This function is available from the front panel mic connector only.
- Be sure to select item “n,” “r,” or “oF” in CW PADDL of the Initial Set mode.
- Connect straight key to “DOT” side.

## ■ Function for RTTY

### ◇ Connection for RTTY (FSK)

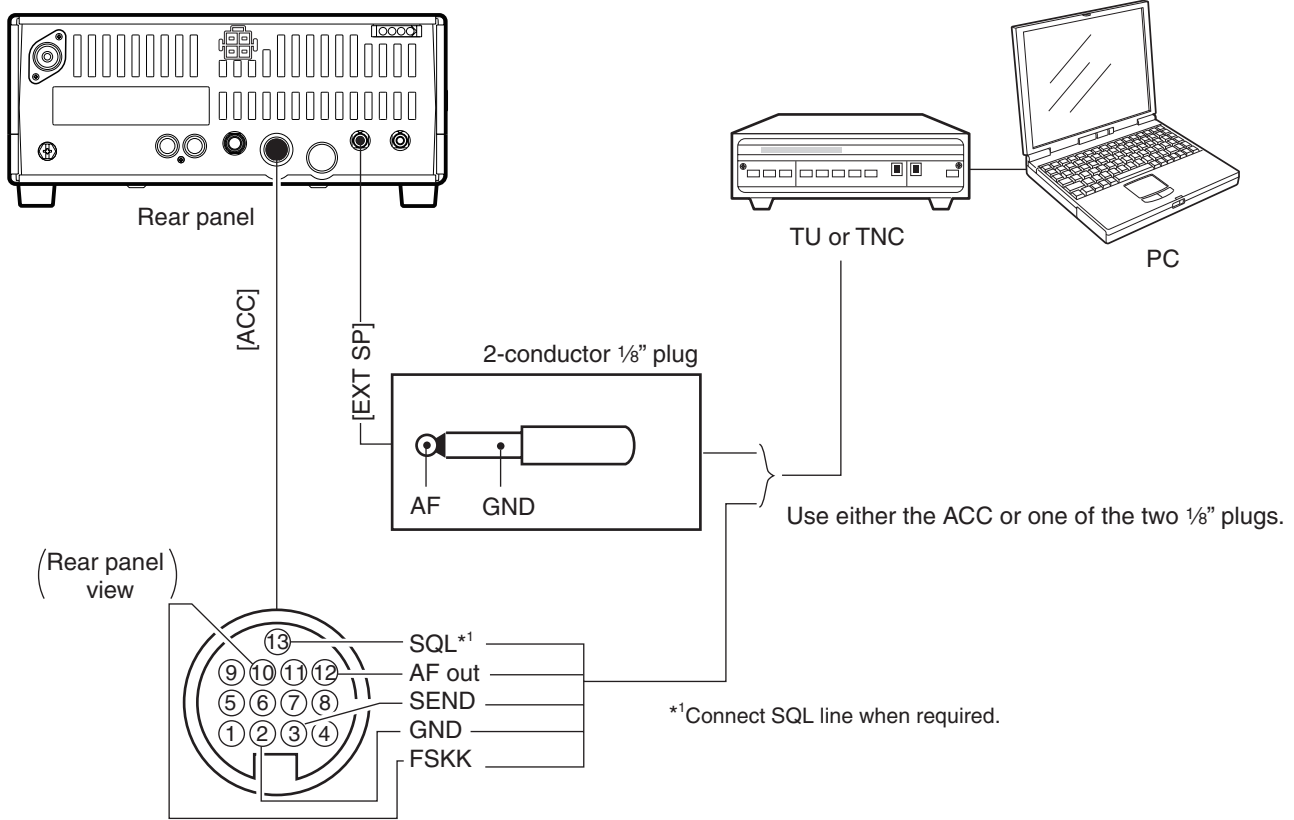

### ◇ Connection for AFSK

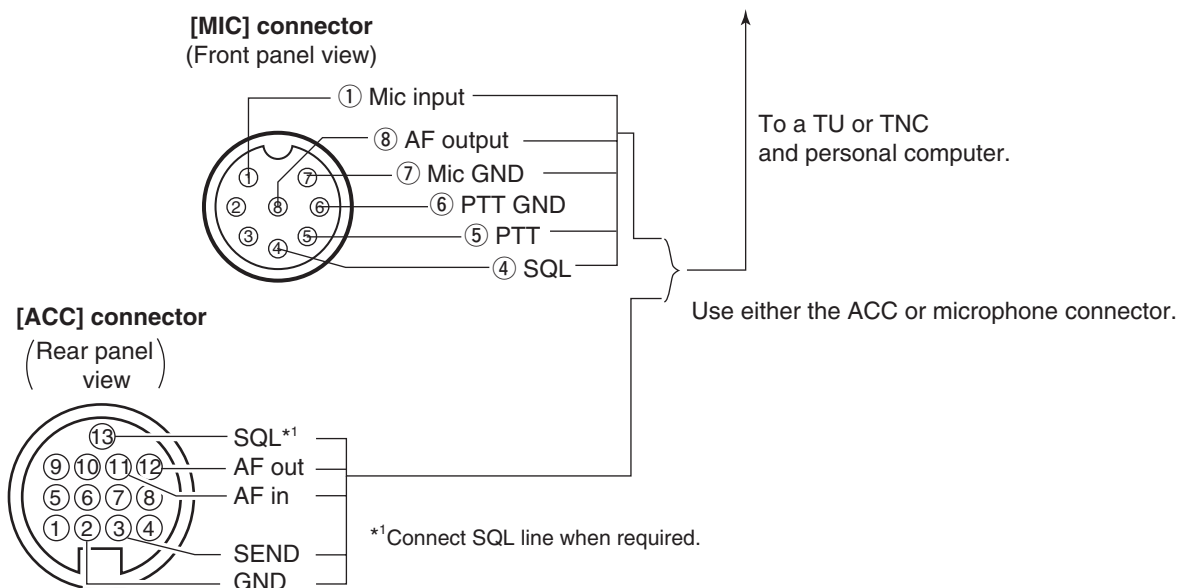

### 3 OPERATION

#### ◇ RTTY (FSK) operation

- ① Connect a terminal unit as on page 24.
- ② Select RTTY (or RTTY-R) mode with [MODE].
- ③ Select the desired FSK tone and shift frequencies as below.
- ④ Set the desired frequency with the Channel Selector.
- ⑤ Operate the connected PC or TNC (TO).

#### PRESETTING FOR RTTY

##### • Tone frequency

- ① Hold down [SET] for 1 second to enter the Quick Set mode.
- ② Push [UP ▲] or [▼ DN] several times until "TON 2125" is displayed, then rotate the Channel Selector to select the desired tone frequency.

##### • Shift frequency

- ① Hold down [SET] for 1 second to enter the Quick Set mode.
- ② Push [UP ▲] or [▼ DN] several times until "SIFT 170" is displayed, then rotate the Channel Selector to select the desired tone frequency.

##### • RTTY reverse mode

Received characters are occasionally garbled when the receive signal is reversed between MARK and SPACE. This reversal can be caused by incorrect TNC connections, settings, commands, and so on.

To receive a reversed RTTY signal correctly, select RTTY-R (RTTY reverse) mode.

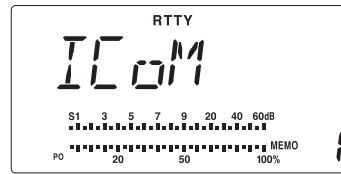

RTTY mode is selected.

- Hold down [MODE] for 1 second to select RTTY-R (RTTY reverse) mode.



RTTY mark frequency is set to 2125 Hz. 2125, 1615 and 1275 Hz are available.



RTTY shift frequency is set to 850 Hz. 850, 425, 200 and 170 Hz are available.

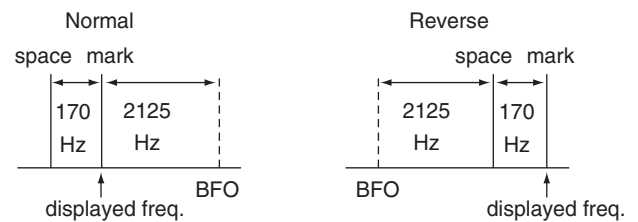

#### ◇ RTTY (AFSK) operation

- ① Connect a terminal unit as on page 24.
- ② Select SSB (LSB) mode with [MODE].
  - Generally, LSB is used on the HF bands.
- ③ Select the desired FSK tone/shift frequencies and keying polarity the same way as FSK operation.
- ④ Set the desired frequency with the main dial.
- ⑤ Operate the connected PC or TNC (TO).

## ■ Channel name entry

You can enter a channel name of up to 8 characters for each Memory channel. This provides easy recognition of channel use or the station name.

- ① Select the desired channel by pushing [UP ▲] or [▼ DN], rotating the Channel Selector, or using the Keypad. (p. 12)
- ② Push [FC] to select a Memory name display, if desired.
- ③ Hold down [ENT] for 1 second to enter the Memory channel name entry mode.
  - The first digit blinks
- ④ Push corresponding keys to enter the desired characters. (See the following chart.)
  - Push [UP ▲] or [▼ DN], or rotate the Channel Selector to move the cursor to select the next character, or to change the digit.
- ⑤ Hold down [ENT] for 1 second to save the channel name.

### • Channel comment programming example

Hold down [ENT] for 1 second

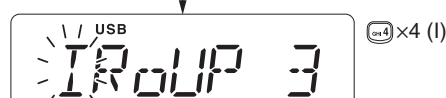
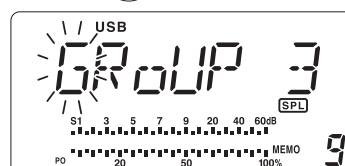

[4] ×4 (I)



[2] ×4 (C)



[6] ×4 (O)



Push [UP ▲] or rotate the Chann Selector, then:

[M] ×2 (M)



[TXF] ×2 (2 spaces)

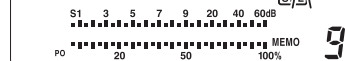

[2] ×1 (2)

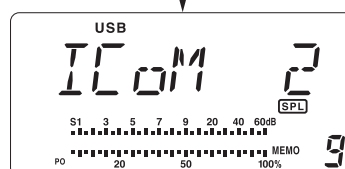

Hold down [ENT] for 1 second

### ◇ Corresponding characters

KEY	Assignable characters	KEY	Assignable characters	KEY	Assignable characters
[1]	1 (1), (space), ' (')	[2]	2 (2), A (A), B (B), C (C)	[3]	3 (3), D (D), E (E), F (F)
[4]	4 (4), G (G), H (H), I (I)	[5]	5 (5), J (J), K (K), L (L)	[6]	6 (6), M (M), N (N), O (O)
[7]	7 (7), P (P), R (R), S (S)	[8]	8 (8), T (T), U (U), V (V)	[9]	9 (9), W (W), X (X), Y (Y)
[TXF]	(space w/change digit)	[0]	0 (0), Q (Q), Z (Z)		

## ■ General

The Set modes are used for setting infrequently changed values or options. The IC-78 has 2 separate set modes, the Quick Set mode and the Initial Set mode.

### ◇ Quick Set mode operation

- ① While power is ON, hold down [SET] for 1 second.
  - The Quick Set mode is selected and one of its items is displayed.
- ② Push [UP ▲] or [▼ DN] to select the desired item.
- ③ Rotate the Channel Selector to set the value or option for the selected item.
- ④ Repeat ② and ③ to set other items.
- ⑤ To exit the Quick Set mode, push [SET].

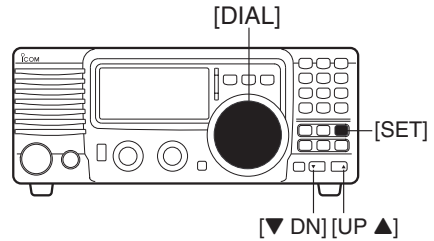

[DISPLAY EXAMPLE: QUICK SET MODE]

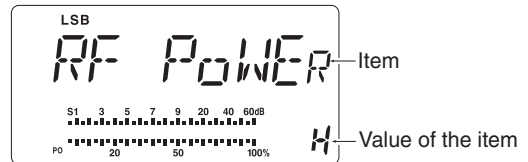

### ◇ Initial set mode operation

- ① Hold down [PWR] for 1 second to turn power OFF.
- ② While holding down [SET], push [PWR] to turn ON the power.
  - The Initial Set mode is selected and one of its items is displayed.
- ③ Push [UP ▲] or [▼ DN] to select the desired item.
- ④ Rotate the main dial to set the value or option for the selected item.
- ⑤ Repeat ③ and ④ to set other items.
- ⑥ To exit the Initial Set mode, hold down [PWR] for 1 second to turn OFF the power.
- ⑦ Push [PWR] to turn ON the power again.
  - The settings in the Initial Set mode are now effective.

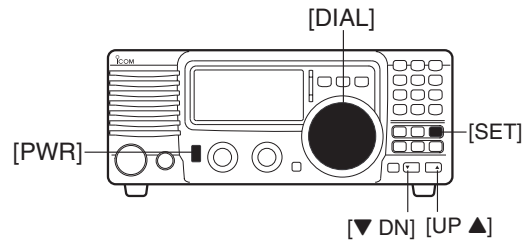

[DISPLAY EXAMPLE: INITIAL SET MODE]

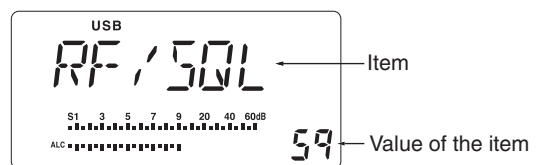

## ■ Quick Set mode items

### • RF power

Adjusts the RF output power. The RF output power can be adjusted from L, 1 to 99 and H by indication, however, it can be adjusted continuously.

•The default is H (maximum power).

Note that while adjusting the output power, the power meter is displayed automatically.

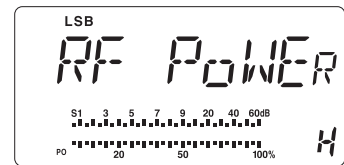

### • Mic gain

Adjusts the microphone gain from 0 to 99 and H (High) by indication, however, it can be adjusted continuously.

The default is 50.

Note that while adjusting the mic gain, the ALC meter is automatically displayed.



### • Filter

Selects the filter bandwidth of wide, normal, or narrow.

The default is normal (no indication is displayed).

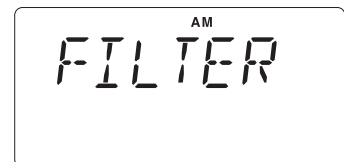

### • VOX function

Selects the VOX (Voice Operated Transmit) function ON or OFF.

The default is of (OFF).



### • VOX gain

Adjusts the VOX gain for VOX operation.

The default is 50.

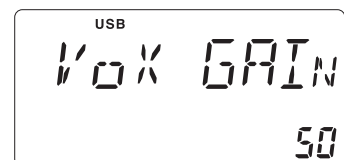

### • VOX delay

Adjusts the VOX delay time. The delay time can be adjusted between 0 and 2 seconds in 0.1 second steps.

The default is 10 (1.0 second).

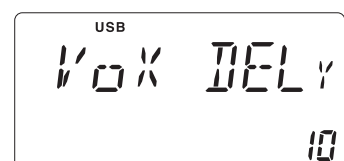

### • Anti VOX level

Adjusts the ANTI-VOX gain for VOX operation.

The default is 50.

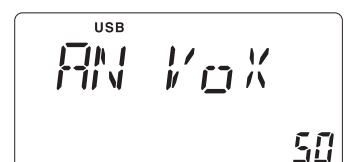

### • CW pitch

Adjusts the CW pitch. CW pitch is adjustable between 300 Hz and 900 Hz in 10 Hz steps.

The default is 60 (600 Hz).

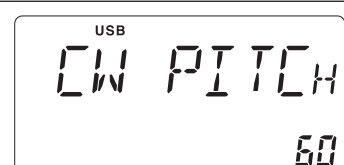

## 4 SET MODE

### ■ Quick Set mode items— (continued)

#### • BK-IN

Selects the break-in type for CW operation.

There are three selectable values:

oF: No break-in operation (default).

SE: Semi break-in operation.

FL: Full break-in operation.

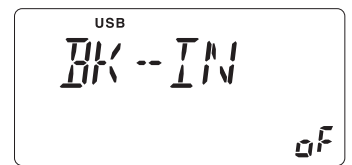

#### • BK-IN delay

Adjusts the break-in delay time for the CW semi break-in operation. The delay time is selectable from 2.0 to 13 (dots).

The default is 7.

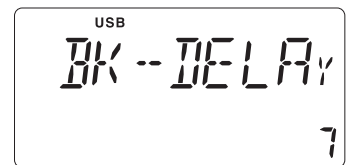

#### • Key speed

Adjusts the CW key speed. Select a speed of 6 to 60\* wpm.

The default is 20 wpm.

\*40, 44, 47, 50, 52, 54, 56, 57, 59 cannot be selected.

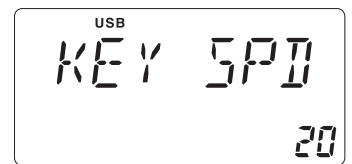

#### • Key ratio

Selects the CW key ratio (or weight). Select a ratio between 2.8 and 4.5.

The default is 30 (3.0).

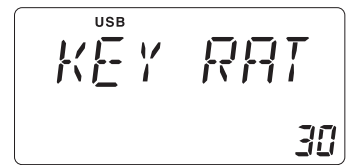

#### • RTTY mark tone

Selects the RTTY tone. Select 1275, 1615, or 2125 Hz.

The default is 2125 Hz.



#### • RTTY shift

Adjusts the RTTY shift. Select 170, 200, 425, or 850.

The default is 170 Hz.

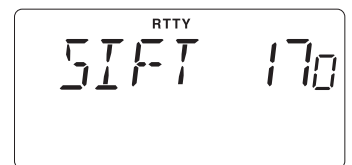

#### • Dimmer

Selects the LCD back light brightness. Select Off, Low, or High.

The default is HI (High).

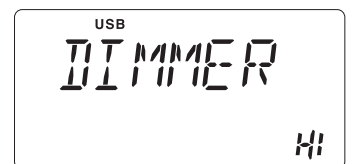

#### • Tuning step

Selects the tuning step for the Channel Selector's tuning.

The default is 1 k (1 kHz).





## ■ Initial Set mode items

### • RF/SQL control action

Selects the [RF/SQL] control action from RF/squelch, automatic (acts as a squelch in AM modes and an RF in SSB/CW/RTTY modes), or the squelch only. (See page 14)

The default is Sq (squelch).

RF / SQL  
59

### • Beep

A beep sounds to confirm each time a switch is pushed. This function can be turned OFF for silent operation.

The default is on.

BEEP  
on

### • Beep level

Adjusts the confirmation beep level from 1 to 99.

The default is 50.

BP LEVEL  
50

### • Side-tone level

Adjusts the CW side-tone level from 1 to 99.

The default is 30.

CW-T LVL  
30

### • Meter peak hold

Selects the meter peak hold function on or off.

The default is on.

P-HOLD  
on

### • Scan speed

Sets the scanning speed to High or Low.

The default is HI (High).

SCN SPD  
HI

### • Scan resume

Turns the scan resume function ON or OFF.

ON: Resumes 10 seconds after stopping on a signal (or 2 seconds after a signal disappears). OFF: Does not resume after stopping on a signal.

The default is on.

SCN RS  
on

### • AM Noise blanker

When set to ON, the noise blanker function is selectable in the AM mode. This is useful when communicating in AM (the noise blanker function should be OFF when listening to regular AM broadcasts as it may degrade the receive audio).

The default is on.

AM NB  
on

## 4 SET MODE

### ■ Initial set mode items— (continued)

#### • Key type

Selects the CW paddle type.

- n: normal (for electronic keyer use)
  - r: reverse (for electronic keyer use)
  - oF: Turns OFF the electronic keyer (for straight key use)
  - ud: When using the microphone's [UP] or [DN] keys instead of the paddle.
- The default is n (normal).

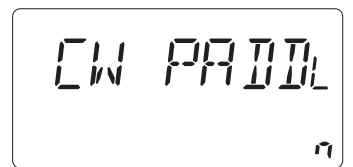

#### • Tuner type

Selects the connected antenna tuner type.

- no: No external tuner is connected.
  - 4: When the AH-4 or AH-740 is connected.
  - 12: When the AT-120 is connected. (No longer produced)
  - 13: When the T-130 is connected.
- The default is no. (none)



#### • Number of maximum memory channels

Sets the number of selectable memory channels from 1 to 99.  
The default is 99.

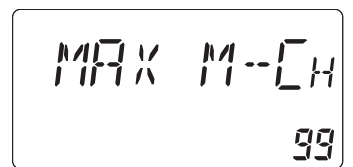

#### • CI-V baud rate

Sets the data transfer rate. When "Auto" is selected, the baud rate is automatically set according to the connected controller or remote controller.  
The default is At (Auto).

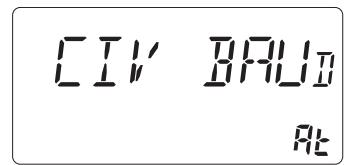

#### • CI-V address

To distinguish equipment, each CI-V transceiver has its own Icom standard address in hexadecimal code. The IC-78's address is 62.

When 2 or more IC-78s are connected to an optional CT-17 CI-V LEVEL CONVERTER, rotate the main dial to select a different address for each IC-78 to between 01 and 7F (Hexadecimal).

The default is 62.

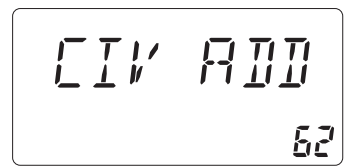

#### • CI-V Transceive

Transceive operation is possible with the IC-78 connected to other Icom HF transceivers or receivers. When "on" is selected, changing the frequency, operating mode, etc. on the IC-78 automatically changes those of connected transceivers (or receivers) and vice versa.

The default is on.

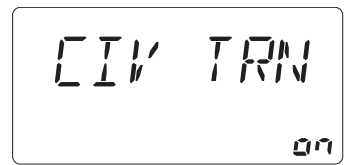

#### • CI-V 731 mode

If you connect the IC-78 to an IC-735 for transceive operation, you must change the operating frequency data to 4 bytes.

- This item MUST be set to "on" when operating the IC-78 using the IC-735.

The default is oF (OFF).

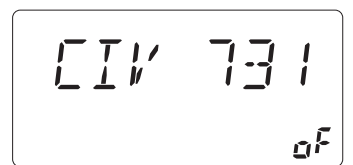

### • Optional filter selection

When an optional IF filter is installed, this selection is necessary, otherwise the optional filter cannot be selected. Select FL-52A,† FL-53A,† FL-96,† FL-222, FL-257 or none (default). See page 21 for usable filters for each mode and see page 38 for filter installation.

The LCD display shows the text 'FIL' on the left and 'no' on the right.

### • Expand filter selection

When an optional IF filter is installed, this selection expands filter and filter selection (W/N) key combination in operating mode independently. The default is oF (OFF).

The LCD display shows the text 'EXP' on the left, 'FIL' on the right, and 'on' at the bottom right.

### • Filter selection (Wide)

When an optional IF filter is installed, you can arrange the wide filter selection. (p. 22)

This item is displayed only when the Expand filter selection, as above, is turned ON.

The LCD display shows 'CW' at the top center, 'WIDE' on the left, and 'THU' on the right.

### • Filter selection (Narrow)

When an optional IF filter is installed, you can arrange the narrow filter selection. (p. 22)

This item is displayed only when the Expand filter selection, as above, is turned ON.

The LCD display shows 'AM' at the top center, 'NAR' on the left, and 'NOR' on the right.

## Introduction

Extra features, explained in this section, are available only on some versions of the IC-78. Therefore, the instructions in this section may not be necessary for some versions.

## VFO operation

### Entering VFO mode

To enter the VFO mode, hold down [FC] for 1 second.

- The VFO icon is displayed.
- In the VFO mode, channels cannot be displayed.

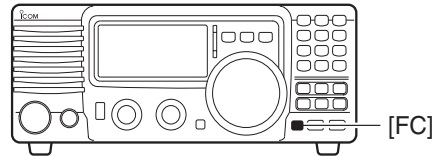

### Tuning

The transceiver has several ways of tuning for temporary operation, as follows.

#### Tuning with the Channel Selector (in the VFO mode)

Rotating the Channel Selector changes the operating frequency in the desired tuning step, set in the Quick Set mode. (p. 29)

This is the most convenient way to search for signals around a pre-entered frequency.

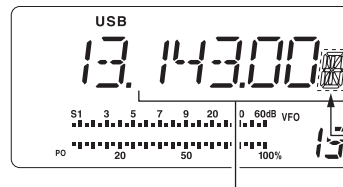

The digit changes according to the selected tuning step.

#### Tuning with the Keypad

Enter the frequency as follows.

##### Start

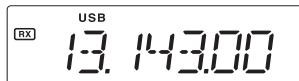

##### To set to 25.118 MHz



##### To set to 706 kHz (0.706 MHz)



##### To set to 5.0000 MHz

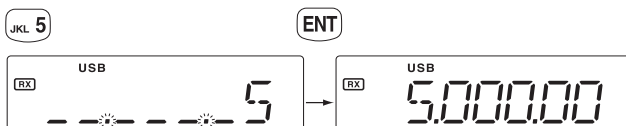

##### To change 13.1430 MHz to 13.3190 MHz



➔ For duplex operation, always first enter the receive frequency and then push [ENT]. Then push [TXF], and enter the transmit frequency and push [ENT].

## ◇ Channel setting

Both the transmit and receive, frequencies in the operating channel can be entered in the VFO mode.

### • Simplex channel programming

- ① Hold down [FC] for 1 second to enter VFO mode.
- ② Push [UP ▲] or [▼ DN] to select the desired channel.
  - Any channels, even blank channels, can be selected.
  - If you want to select the desired channel with the Keypad, select the channel before entering the VFO mode.
- ③ Tune to the desired receive frequency with the Channel Selector, or Keypad. (p. 33)
  - Selects operating mode and other settings, such as filter selection, RF attenuator, and so on, if necessary.
- ④ Hold down [ENT] for 1 second (3 beeps are emitted), to store the frequency into the selected channel.
  - Reprogram the channel name, if necessary. (p. 26)

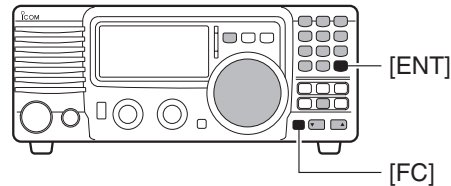

### • Split (duplex) channel setting

- ① Save receive frequency as described above.
- ② Push [TXF] to display the transmit frequency.
  - The "TX" icon blinks.
- ③ Tune to the desired transmit frequency with the Channel Selector, or Keypad. (p. 33)
- ④ Hold down [ENT] for 1 second (3 beeps sound), to save the transmit frequency into the selected channel.
  - The "[SPL]" icon is displayed.

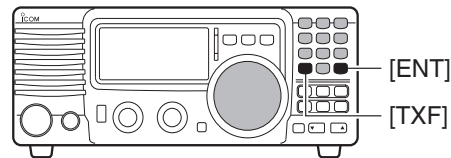

## ◇ Call channel setting

Both the transmit and receive frequencies in the Call channel can also be entered in the VFO mode.

- Select channel 0 (Call channel) with the Keypad in the Channel mode or push [UP ▲] or [▼ DN] in the VFO mode.
  - Channel 0 cannot be selected using the Channel Selector
  - When Channel 0 is selected using [CALL], the saved frequencies cannot be preset.
  - Holding down [FC] for 1 second to enter the VFO mode when channel 0 is selected in channel mode.

- Set the receive frequency or both the receive and transmit frequencies, operating mode and other settings as described above, then hold down [ENT] for 1 second to save them in the Call channel.

## 5 EXTRA FEATURES

### ◇ Clearing a Memory channel

If there are unnecessary channels, they can be cleared. The cleared channels are skipped in the channel mode operation,

- ① Select desired channel in channel mode. (p. 12)
- ② Enter VFO mode by holding down [FC] for 1 second.
  - Channel selection by pushing [UP ▲] or [▼ DN] is also possible in the VFO mode.
- ③ Push [0], then [ENT].
- ④ Hold down [ENT] for 1 second (3 beeps are emitted), to clear the selected channel.
  - The “**BLANK**” icon is displayed.

**Note:** Blank channels cannot be selected by pushing [UP ▲] or [▼ DN], and Channel Selector. It can be selected with the Keypad.

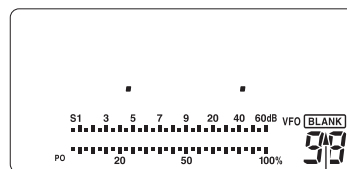

Appears when cleared.

## ■ 2-Tone alarm operation

The 2-tone alarm is used for instant emergency operation. When the 2-tone alarm function is activated, the call channel (the 2182 kHz, distress channel is pre-set) is automatically selected, and a distress alarm sounds.

### ◇ Operation

- Push [TONE] to sound a distress alarm signal for a specified time period from the speaker only.
  - The “**ALM**” icon is displayed.
  - Push [TONE] again to cancel the distress alarm signal.
  - Push [CALL] to return to previous operation.
- Hold down [TONE] for 1 second to transmit a distress alarm or alarm testing signal for a specified time period.
  - The “**ALM**” icon and the Transmit icon are displayed.
  - Push [TONE] again to cancel the distress alarm signal transmission.
  - Push [CALL] to return to previous operation.

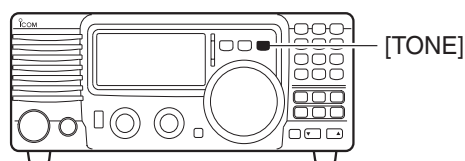

## ■ Opening the transceiver's case

Follow the case and cover opening procedures shown below when you want to install an optional unit or adjust an internal unit, and so on.

**CAUTION:** DISCONNECT the DC power cable from the IC-78 before performing any work on the transceiver. Otherwise, there is danger of electric shock and/or equipment damage.

- ① Remove the 5 screws from the top of the transceiver and 4 screws from the sides, then lift up the top cover.
- ② Remove the 5 screws from the bottom of the transceiver, then remove the bottom cover.

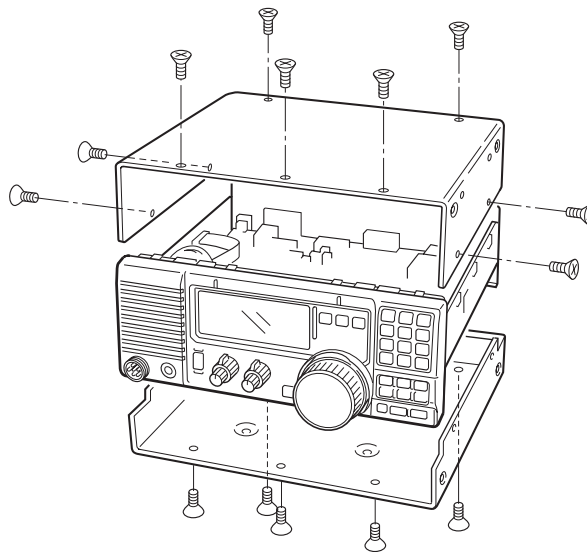

## ■ Optional bracket and carrying handle

### ◇ Mounting bracket

The universal mounting bracket allows overhead mounting.

#### **Installation**

Securely mount the transceiver with the 4 supplied screws (5 x 20) to a thick surface which can support more than 3.8 kg.

**CAUTION:** Non-supplied bolts (longer than 8 mm) may damage the internal units.

**NEVER** install the MB-118 with non-supplied screws and bolts.

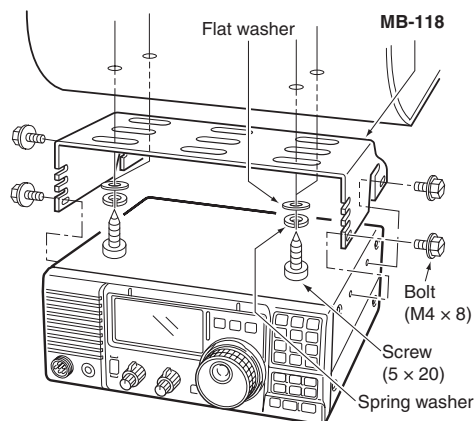

### ◇ Carrying handle

An optional handle allows you to easily carry the transceiver.

Attach the MB-23 CARRYING HANDLE and the supplied rubber feet, as shown.

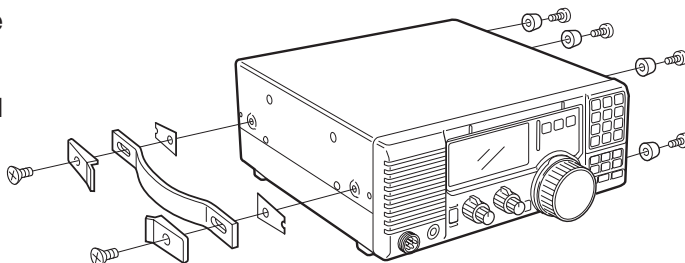

## 6 OPTION INSTALLATION

### ■ CR-338 HIGH STABILITY CRYSTAL UNIT

By installing the CR-338, the total frequency stability of the transceiver will be improved.

- ① Remove the bottom cover as shown in the previous diagram.
- ② Disconnect W2 from J4401 (MAIN unit) and W3 from J4201 (MAIN unit).
- ③ Remove 9 screws from the PLL unit, disconnect P4 from J201 (MAIN unit) and P2 from J401 (MAIN unit), then remove the PLL unit.

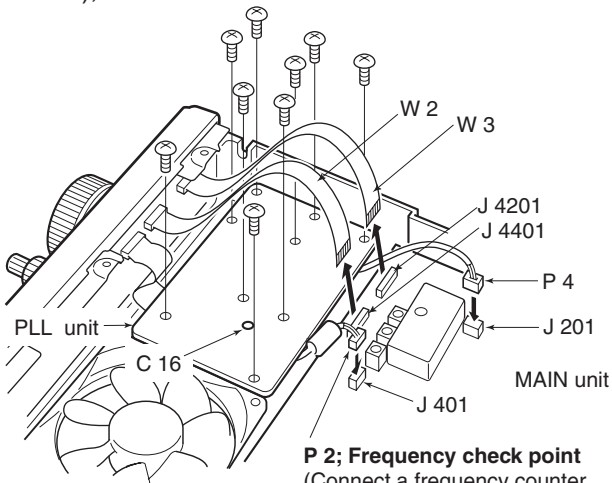

**P 2; Frequency check point**  
(Connect a frequency counter and adjust the frequency to 64.00000 MHz with C 16.)

- ④ Remove the standard internal crystal and replace it with the CR-338.

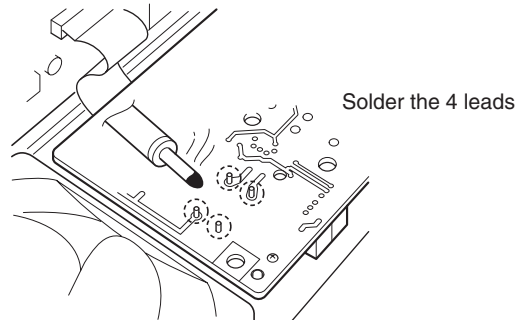
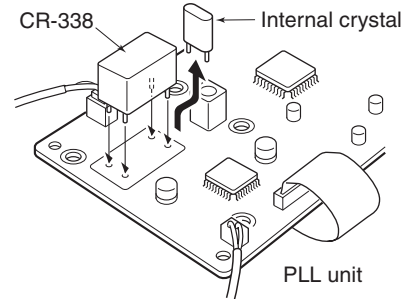

- ⑤ Return the PLL unit, plugs and flat cables to their original positions.
- ⑥ Adjust the reference frequency with C16 using a frequency counter, if desired.
  - Connect the frequency counter to P 2 (PLL unit).
- ⑦ Return the bottom cover to its original position.

### ■ Optional IF filters

Several IF filters are available for the IC-78. You can install one 455 kHz IF filter. Choose the appropriate filter for your operating needs. (pp, 20, 21)

#### ◆ Installation

- ① Remove the bottom cover as shown on page 47.
- ② Remove 7 screws, connection cable P1 from J1, P5 from J701, W4 from J4101 and W5 from J4001 and 2 Tr-clampers as shown in the diagram below.

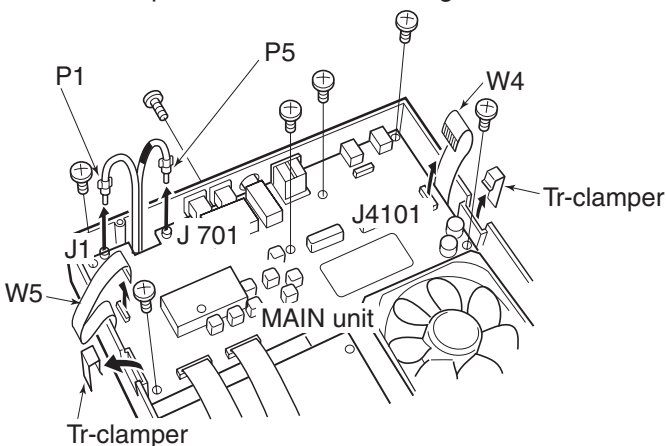

- ③ Install the desired 455 kHz filter, as shown in the diagram to the right.
- ④ Mount the filter with the supplied washers and nuts.

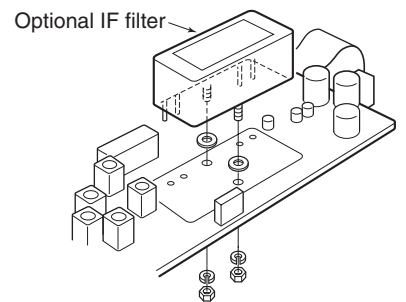

- ⑤ Solder the 4 leads.
- ⑥ Return the MAIN unit and bottom cover to their original positions.

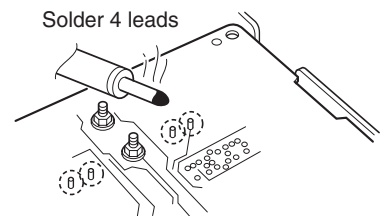

After filter installation, specify the installed filter using the Initial Set mode. (p. 32) Otherwise, the installed filter will not function properly.



## ■ Troubleshooting

The following chart is designed to help you correct problems which are not equipment malfunctions.

If you are not able to locate the cause of the problem, or solve it through the use of this chart, contact your nearest Icom dealer or Service Center.

	PROBLEM	POSSIBLE CAUSE	SOLUTION	REF.
POWER	Power does not come on when the [PWR] switch is pushed.	<ul style="list-style-type: none"> <li>• Power cable is improperly connected.</li> <li>• Fuse is blown.</li> </ul>	<ul style="list-style-type: none"> <li>• Reconnect the DC power cable correctly.</li> <li>• Check for the cause, then replace the fuse with a rated one. (Fuses are installed in the DC power cable and the internal PA unit.)</li> </ul>	p. 10 p. 39
RECEIVE	No sounds comes out of the speaker.	<ul style="list-style-type: none"> <li>• Volume level is set too low.</li> <li>• The squelch is closed.</li> <li>• The transceiver is transmitting.</li> </ul>	<ul style="list-style-type: none"> <li>• Rotate [AF] clockwise to obtain a suitable listening level.</li> <li>• Turn [RF/SQL] to the position that just opens the squelch.</li> <li>• Check the SEND line of an external unit.</li> </ul>	p. 14 p. 14 p. 4
	Sensitivity is too low, and only strong signals are heard.	<ul style="list-style-type: none"> <li>• The antenna is not properly connected.</li> <li>• The antenna is not properly matched to the operating frequency.</li> <li>• The wrong tuner value is selected in set mode.</li> <li>• The attenuator is activated.</li> </ul>	<ul style="list-style-type: none"> <li>• Reconnect to the antenna connector.</li> <li>• Push [TUNE] to tune the connected antenna tuner.</li> <li>• Set the proper value for the connected tuner.</li> <li>• Push [ATT] to turn the attenuator OFF.</li> </ul>	p. 8 p. 17 p. 31 p. 18
	Received audio is unclear or distorted.	<ul style="list-style-type: none"> <li>• The wrong mode is selected.</li> <li>• The noise blanker is turned ON when receiving a strong signal.</li> <li>• The [RIT] control is rotated too far clockwise, or counterclockwise.</li> </ul>	<ul style="list-style-type: none"> <li>• Push [MODE] to select the proper operating mode.</li> <li>• Push [NB] to turn the noise blanker OFF.</li> <li>• Adjust the [RIT] control to receive proper audio output.</li> </ul>	p. 14 p. 18 p. 18
TRANSMIT	Your signal does not reach as far as usual.	<ul style="list-style-type: none"> <li>• The antenna tuner is not matched to the operating frequency when manual tuning is selected.</li> <li>• The CW or RTTY mode is selected for voice transmission.</li> </ul>	<ul style="list-style-type: none"> <li>• Push [TUNE] to tune the external antenna tuner.</li> <li>• Push [MODE] to select USB, LSB, or AM mode.</li> </ul>	p. 17 p. 14
	Transmit signal is unclear or distorted.	<ul style="list-style-type: none"> <li>• The wrong mode is selected.</li> <li>• Microphone is too close to your mouth.</li> </ul>	<ul style="list-style-type: none"> <li>• Push [MODE] to select the proper operating mode.</li> <li>• Speak into the microphone at your normal voice level. Hold the mic farther away from your mouth.</li> </ul>	p. 14 p. 14
DISPLAY	The displayed channel does not properly change.	<ul style="list-style-type: none"> <li>• The dial lock function is activated.</li> <li>• The Quick Set mode is selected.</li> </ul>	<ul style="list-style-type: none"> <li>• Push [LOCK] to turn the Lock function OFF.</li> <li>• Push [SET] to exit the Quick Set mode.</li> </ul>	p. 13 p. 27

## ■ Fuse replacement

If a fuse blows, and the transceiver stops functioning, find the source of the problem, and repair it. Then replace the damaged fuse with a new, adequately rated fuse.

**CAUTION:** Turn the power OFF and disconnect the DC power cable from the transceiver before removing the transceiver's cover.

The IC-78 has 2 types of fuses installed for transceiver protection.

- DC power cable fuses ..... ATQ 25 A
- Circuitry fuse ..... FGB 4 A

### DC POWER CABLE FUSE REPLACEMENT

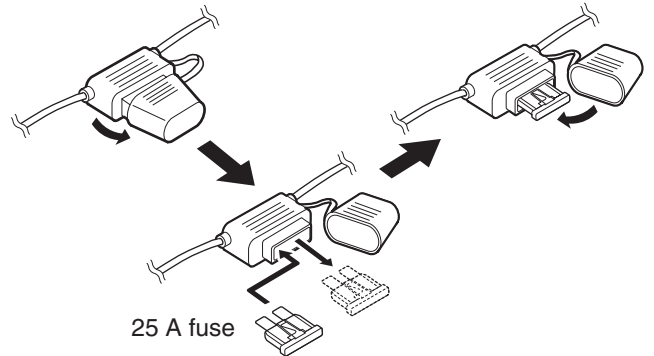

### CIRCUITRY FUSE REPLACEMENT

The 13.8 V DC from the DC power source is applied to all units in the IC-78 through the circuitry fuse. This fuse is in the PA unit.

- ① Remove the top cover as shown on page 47.
- ② Replace the circuitry fuse as shown in the diagram to the right.
- ③ Replace the top cover.

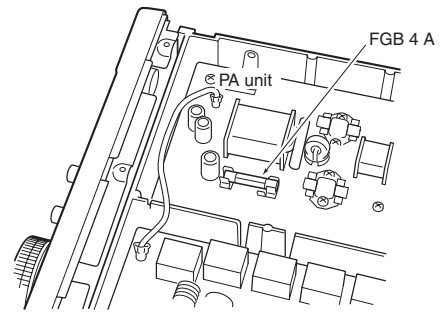

## ■ Resetting the CPU

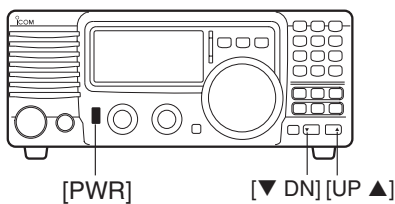

Returns programmed values in both the Quick and Initial Set modes to their defaults.

When applying power for the first time after purchase, or if the functions seem to be displaying erroneous information, reset the CPU as follows:

- ① Make sure transceiver power is OFF.
- ② While pushing [UP ▲] and [▼ DN], push [PWR] to turn power ON.
  - The internal CPU is reset.

## ■ CI-V remote control

### • CI-V connection example

The transceiver can be connected through an optional CT-17 CI-V LEVEL CONVERTER to a personal computer equipped with an RS-232C port. The Icom Communications Interface-V (CI-V) controls the following functions of the transceiver.

Up to 4 Icom CI-V transceivers or receivers can be connected to a personal computer equipped with an RS-232C port, or through an RS-232 to USB Serial adapter. See page 31 for setting the CI-V condition using set mode.

### • Data format

The CI-V system can be operated using the following data formats. Data formats differ, depending on command numbers. A data area or sub command is added to some commands.

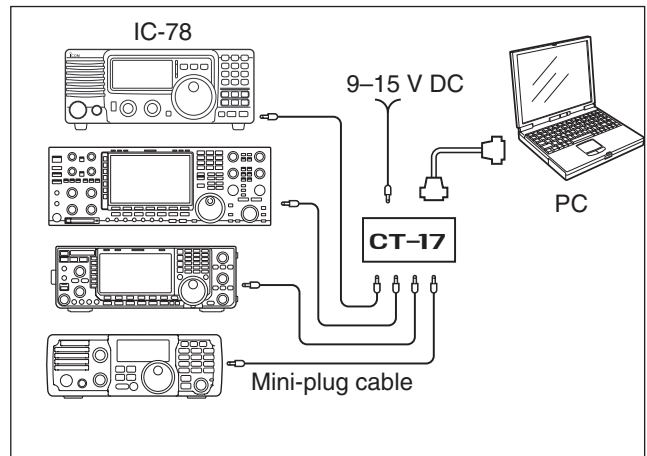

#### CONTROLLER TO IC-78

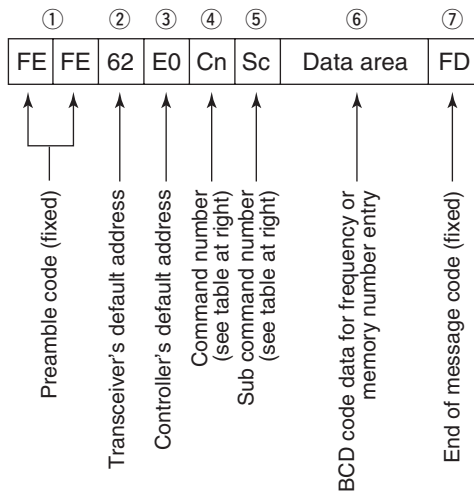

#### OK MESSAGE TO CONTROLLER

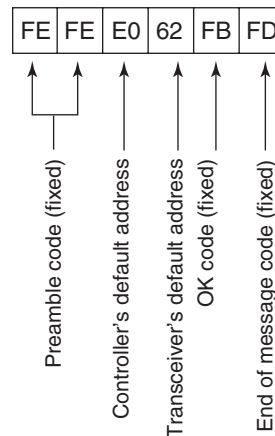

#### IC-78 TO CONTROLLER

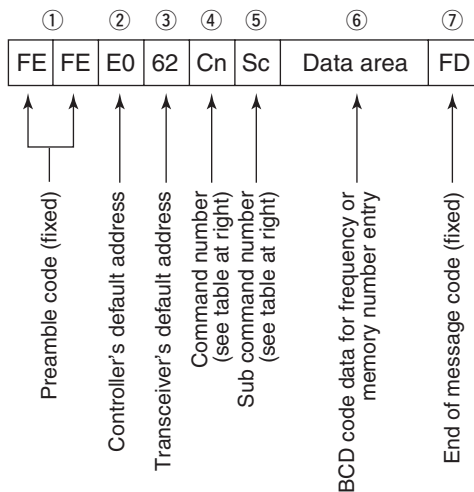

#### NG MESSAGE TO CONTROLLER



## 8 CONTROL COMMAND

### • Command table

Command	Sub command	Description
00	—	Send frequency data
01	—	Send mode data
02	—	Read Upper/Lower frequencies
03	—	Read frequencies
04	—	Read operating mode
05	—	Set operating frequency
06	—	Set mode
08	—	Set memory
	—	Set memory channel
0E	00	Scan stop
	01	Memory scan start
11	—	ATT
14	01	AF gain
	02	RF gain
	03	Squelch level
15	01	Read squelch Open/Close
	02	Read S-meter level
16	02	PREAMP
	22	Noise blanker
	44	Microphone compressor
19	00	Read ID

## ■ Data cloning between transceivers

### • Data cloning

The IC-78's data (Entered frequencies, channel names, both the Quick and Initial Set mode values, and so on.) can be copied to another IC-78. This function is useful when exactly the same settings of the IC-78s are required.

### • Cloning operation

- ① Turn power OFF.
- ② Connects a mini-plug cable between two IC-78's (Master and Sub) [REMOTE] jack.
 

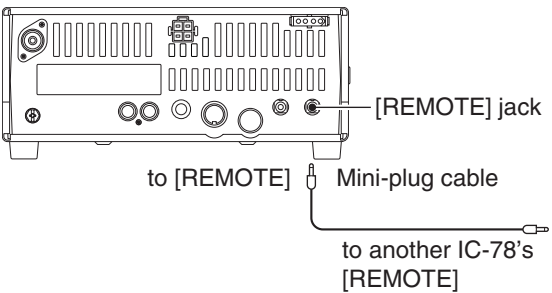

[REMOTE] jack

to [REMOTE] Mini-plug cable to another IC-78's [REMOTE]
- ③ While holding down [TXF] and [FC], turn the Master IC-78 power ON.
- ④ While pushing [SET] and [FC], turn the Sub IC-78 power ON.
 

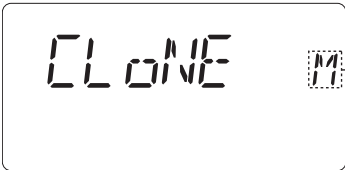

Master transceiver displays "M."
- ⑤ Push [TONE] of the Master IC-78 to start cloning.
 

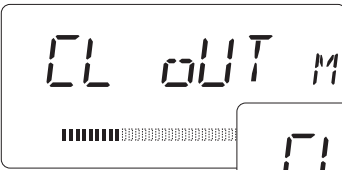

Master transceiver display

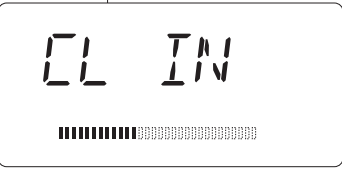

Sub transceiver display
- After cloning complete;
 

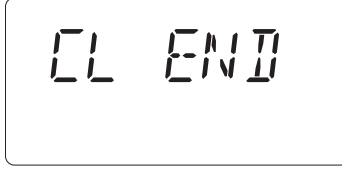

Sub transceiver display
- ⑥ Turn OFF the power.

## ■ GENERAL

- Frequency range:
 

Rx	0.030000–29.999999 MHz*1
Tx	1.600000–29.999999 MHz*2
- \*1Guaranteed range: 0.5–29.999999 MHz
- \*2Not guaranteed for some frequency bands
- Mode: USB, LSB, CW, RTTY, AM
- Number of memory channels: 99 (Duplex) +1 Call
- Frequency stability:
 

Less than  $\pm 200$  Hz from 1 to 60 minutes after power ON. After that, the rate of stability is less than  $\pm 30$  Hz/hr. at  $+25^{\circ}\text{C}$  ( $+77^{\circ}\text{F}$ ). Temperature fluctuations  $0^{\circ}\text{C}$  to  $+50^{\circ}\text{C}$  ( $+32^{\circ}\text{F}$  to  $+122^{\circ}\text{F}$ ) less than  $\pm 350$  Hz
- Power supply requirement (negative ground): 13.8 V DC  $\pm 15\%$
- Current drain (at 13.8 V DC):
 

Receive	Stand-by	1.3 A
	max. audio	2.0 A
Transmit	max. power	21.0 A
- Operating temp. range:  $-10^{\circ}\text{C}$  to  $+60^{\circ}\text{C}$ ,  $+14^{\circ}\text{F}$  to  $+140^{\circ}\text{F}$
- Antenna connector: SO-239 (50  $\Omega$ )
- Dimensions: 240 (W)  $\times$  95 (H)  $\times$  239 (D) mm (projections not included) 9.5 (W)  $\times$  3.7 (H)  $\times$  9.4 (D) in
- Weight (approximately): 3.8 kg, 8 lb 6 oz
- ACC connector: 13 pin

## ■ TRANSMITTER

- Modulation system:
 

SSB	Balanced modulation
AM	Low level modulation
- Output power:
 

SSB, CW, RTTY	2–100 W
AM	2–35 W
- Spurious emissions: Less than  $-46$  dB below peak output power
- Carrier suppression: More than 40 dB
- Unwanted sideband: More than 50 dB
- Microphone connector: 8 pin connector (600  $\Omega$ )

## ■ RECEIVER

- Receiver system: Double-conversion superheterodyne
- Sensitivity (10 dB S/N):
 

SSB, CW, RTTY	0.16 $\mu\text{V}$ (1.600–29.999999 MHz) (0.5 $\mu\text{V}$ at 12 dB SINAD)
AM	13 $\mu\text{V}$ (0.5–1.599999 MHz) 2 $\mu\text{V}$ (1.600–29.999999 MHz)
- Selectivity:
 

SSB, CW, RTTY	More than 2.1 kHz/ $-6$ dB Less than 4.5 kHz/ $-60$ dB
AM	More than 6.0 kHz/ $-6$ dB Less than 20 kHz/ $-40$ dB
- Spurious and image rejection ratio: (1.600–29.999999 MHz) More than 70 dB
- Audio output power: More than 2.0 W at 10% distortion into an 8  $\Omega$  load (at 13.8 V DC)
- RIT variable range:  $\pm 1200$  Hz
- PHONES connector: 3 conductor 6.5 (d) mm ( $1/4$ "
- Ext. SP connector: 2 conductor 3.5 (d) mm ( $1/8$ " /8  $\Omega$ )

**All stated specifications are typical and subject to change without notice or obligation.**

# 10 OPTIONS

## AT-130/E

AUTOMATIC ANTENNA TUNER



Matches the transceiver to a long wire antenna with a minimum of insertion loss.

## AH-4 AUTOMATIC ANTENNA TUNER



Specially designed to tune a long wire antenna for portable or mobile HF operation. The PTT tuner start function provides simple operation.

- Input power rating: 120 W

## AH-740 AUTOMATIC TUNING ANTENNA



Highperformance, automatic high-speed tuning antenna.

- Frequency coverage  
With 1.54 m whip antenna:  
2.5 MHz–29.9999 MHz  
With AH-5NV (NVIS kit):  
2.2 MHz–29.9999 MHz

## AH-2b ANTENNA ELEMENT



A 2.5 m long antenna element for mobile operation with the AH-4.

- Frequency coverage:  
3.5–28 MHz  
bands with the  
AH-4

## AH-710 FOLDED DIPOLE ANTENNA

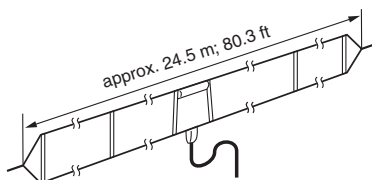

Covers the 1.9–30 MHz bands. Has an SO-239 connector. A 30 m (98.4 ft) coaxial cable with PL-259 connector is supplied.

## HM-36 HAND MICROPHONE



Hand microphone equipped with [UP] and [DOWN] switches.

Same as the supplied microphone.

## SM-30 DESKTOP MICROPHONE



Includes a low frequency cut function.

## SM-50 DESKTOP MICROPHONE



Unidirectional, dynamic microphone for base station operation. Includes [UP]/ [DOWN] switches, a low cut switch and mic gain control.

## PS-126 DC POWER SUPPLY



- Output voltage: 13.8 V DC
- Maximum output current: 25 A

## MN-100 ANTENNA MATCHER



Matches the transceiver to a dipole antenna. Covers all HF bands from 1.5 to 30 MHz. Two 8 m antenna wires are supplied.

## MN-100L ANTENNA MATCHER



Matches the transceiver to a long wire antenna. Covers all HF bands from 1.5 to 30 MHz. One 15 m antenna wire is supplied.

## SP-23 EXTERNAL SPEAKER



4 audio filters, headphone jack, can be connected to 2 transceivers.

- Input impedance: 8  $\Omega$
- Maximum input power: 4 W

**FL-222 and FL-257**  
455 kHz FILTERS



- FL-222: 1.8 kHz/–6 dB (SSB narrow)
- FL-257: 3.3 kHz/–6 dB (SSB wide)

**CR-338**  
HIGH-STABILITY CRYSTAL UNIT



Contains a temperature-compensating oven heater and crystal unit for improved frequency stability.

- Frequency stability:  $\pm 0.5$  ppm

**MB-23 CARRYING HANDLE**



Carrying handle, convenient for portable operation.

**MB-118 MOBILE MOUNTING BRACKET**



For mounting the transceiver in a vehicle.

**CT-17 CI-V LEVEL CONVERTER**



For remote transceiver control using a PC. You can change frequencies, operating mode, Memory channels and so on.

**AH-5NV NVIS KIT**  
Approximately 4.5 m (14.8 ft) long antenna for the AH-740.  
Frequency coverage with AH-740: 2.2 MHz – 29.9999 MHz

**OPC-420 4-CONDUCTOR SHIELD CABLE**  
For the connection between transceiver and an antenna tuner AT-130 or AH4. Compatible with the control cable, that is supplied with the AT-130 or AH-4.  
Cable length: 10 m (32.8 ft)

**OPC-599 ADAPTER CABLE**  
13-pin, ACC connector to 7-pin + 8-pin ACC connector.

**OPC-2321 CONTROL CABLE**  
For the connection between transceiver and AH-740.  
Cable length: Approximately 6 m (19.7 ft)

**Count on us!**



---

---

---

---

---

---

---

---